

Operator's Manual

optris[®] CoolingJacket Advanced



Cooling housing for PI series, infrared video thermometer and infrared thermometer at high ambient temperatures

Optris GmbH

Ferdinand-Buisson-Str. 14
13127 Berlin
Germany

Tel.: +49 30 500 197-0
Fax: +49 30 500 197-10

E-mail: info@optris.global
Internet: www.optris.global



Table of contents

Table of contents	3
1 General notes	6
1.1 Intended use	6
1.2 Warranty	7
1.3 Scope of supply	8
1.3.1 Versions	8
1.4 Mounting accessories	9
1.4.1 Accessories for PI Netbox	9
1.4.2 Accessories for USB Server Gigabit	10
2 Technical Data	11
2.1 General specifications	11
2.1.1 Focusing unit and front part	12

2.2	Accessories.....	14
2.2.1	High temperature cable	14
2.2.2	Protection window.....	15
2.2.3	Mounting flange	16
2.2.4	Laminar air purge.....	16
2.2.5	Additional accessories	19
2.3	Dimensions	20
2.4	Fittings	29
2.4.1	Cooling water fitting	29
2.4.2	Air purge collar.....	29
2.4.3	Cable glands on the back	31
2.5	Cooling properties.....	32
2.5.1	Condensation.....	32

3	Installation	35
3.1	Installation.....	35
3.2	Installation of PI camera, infrared video thermometer and infrared thermometer.....	36
3.2.1	Assembling of the focusing unit.....	36
3.2.2	Assembling of the front part.....	40
3.2.3	Mounting of protective window at focusing unit.....	43
3.2.4	Assembly of the laminar air purge	45
3.2.5	Assembling to the standard version	47
3.2.6	Assembling to the extended version.....	58
4	Example of installation.....	70

1 General notes

1.1 Intended use

Thank you for choosing the **optris® CoolingJacket Advanced** cooling housing.

The cooling housing CoolingJacket Advanced is intended to use for optris® PI series, video thermometers CTvideo and CSvideo as well as CTlaser and CSLaser for application at high ambient temperatures.



- Read the manual carefully before the initial start-up. The producer reserves the right to change the herein described specifications in case of technical advance of the product.
- In case of problems or questions which may arise when you use the infrared camera, please contact our service department.



- ▶ All accessories can be ordered according to the referred part numbers in brackets [].

1.2 Warranty

Each single product passes through a quality process. Nevertheless, if failures occur contact the customer service at once. The warranty period covers 24 months starting on the delivery date. After the warranty is expired the manufacturer guarantees additional 6 months warranty for all repaired or substituted product components. Warranty does not apply to damages, which result from misuse or neglect. The warranty also expires if you open the product. The manufacturer is not liable for consequential damage or in case of a non-intended use of the product.

If a failure occurs during the warranty period the product will be replaced, calibrated or repaired without further charges. The freight costs will be paid by the sender. The manufacturer reserves the right to exchange components of the product instead of repairing it. If the failure results from misuse or neglect the user has to pay for the repair. In that case you may ask for a cost estimate beforehand.

1.3 Scope of supply

1.3.1 Versions

CoolingJacket Advanced (Standard or Extended) with mounting bracket and installation instructions

Standard	Extended
<p>CoolingJacket Advanced for PI series</p> <p>[Part-No.: ACPICJAS], consisting of housing incl. chassis</p> <p>[Part-No.: ACCJAxxxx], consisting of focusing unit (PI 160/ PI 4xx/ PI 640) or front part (PI 2xx/ PI 1M/ PI 05M)</p>	<p>CoolingJacket Advanced for PI series</p> <p>[Part-No.: ACPICJAEx], consisting of housing incl. chassis</p> <p>[Part-No.: ACCJAxxxx], consisting of focusing unit (PI 160/ PI 4xx/ PI 640) or front part (PI 2xx/ PI 1M/ PI 05M)</p>
<p>CoolingJacket Advanced for CSlaser, CTlaser as well as CTvideo and CSvideo</p> <p>[Part-No.: ACCTLCJAS], consisting of housing incl. chassis</p> <p>[Part-No.: ACCJAFPCTL], consisting of front part</p>	<p>CoolingJacket Advanced for CSlaser, CTlaser as well as CTvideo and CSvideo</p> <p>[Artikel-Nr.: ACCTLCJAE], consisting of housing incl. chassis</p> <p>[Artikel-Nr.: ACCJAFPCTL], consisting of front part</p>
	<p>incl. mounting accessories for</p> <ul style="list-style-type: none"> • PI Netbox or USB server Gigabit • Industrial PIF

1.4 Mounting accessories

1.4.1 Accessories for PI Netbox

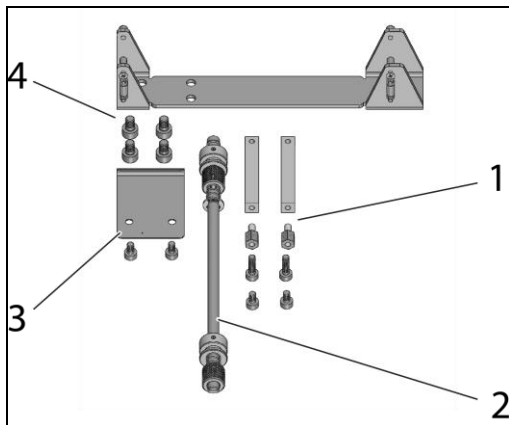

Figure 1: Accessories for PI Netbox

- 1 Support rods for Industrial PIF (2x distance bolt SW 5,5x6 - M3x6, 2x cylinder head screw M3x10 and 2x cylinder head screw M3x5)
- 2 Shaft for fixing the PI Netbox
- 3 Holding plate (2x cylinder head screw M3x5)
- 4 Fastening rail (4x cylinder head screw M4x8)

1.4.2 Accessories for USB Server Gigabit

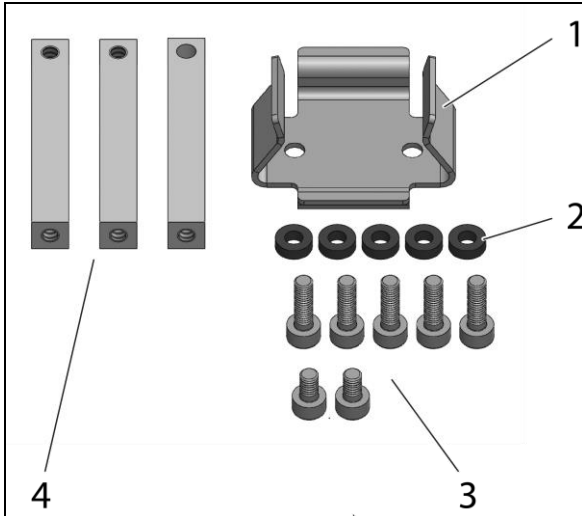

Figure 2: Accessories for USB-Server Gigabit

- 1 DIN rail plate for fixing the USB server Gigabit
- 2 Distance rings
- 3 Screws
- 4 Support rods for Industrial PIF, with thread and without

2 Technical Data

2.1 General specifications

	CoolingJacket Advanced Standard	CoolingJacket Advanced Extended
Environmental rating	IP 65	IP 65
Ambient temperature	up to 315 °C ¹⁾	up to 315 °C ¹⁾
Relative humidity	10...95 %, non-condensing	10...95 %, non-condensing
Material (housing)	V2A	V2A
Dimensions	271 mm x 166 mm x 182 mm	426 mm x 166 mm x 182 mm
Weight	5.7 kg	7.8 kg
Air purge collar	G1/4" Internal thread G3/8" External thread	G1/4" Internal thread G3/8" External thread
Cooling water fittings	G1/4" Internal thread G3/8" External thread	G1/4" Internal thread G3/8" External thread
Cooling water pressure	15 bar (217 psi)	15 bar (217 psi)

¹⁾ Cable available up to 250 °C ambient temperature as well as cable cooling up to 315 °C.

2.1.1 Focusing unit and front part

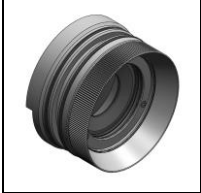

PI 160

Focusing unit

for 6°, 41° and 72° optics [**Part-No.: ACCJAFU6**]

for 23° optics [**Part-No.: ACCJAFU23**]

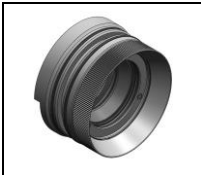

PI 4xx/ PI 640

Focusing unit

for 13° optics [**Part-No.: ACCJAFU13**]

for 15° optics [**Part-No.: ACCJAFU15**]

for 29° optics (PI 4xx) and 33° optics (PI 640) [**Part-No.: ACCJAFU38**]

for 53° optics (PI 4xx) and 60° optics (PI 640) [**Part-No.: ACCJAFU60**]

for 80° optics (PI 4xx) [**Part-No.: ACCJAFU80**]

for 90° optics (PI 640) [**Part-No.: ACCJAFU90**]



Front part

for 23° and 41° optics (PI 2xx) [**Part-No.: ACCJAFP2XX**]

PI 2xx



Front-part

for all optics (PI 1M/ 05M) incl. protection window [**Part-No.: ACCJAFP1M**]

PI 1M/ 05M

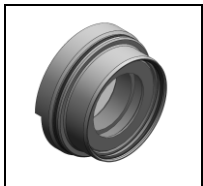

Front part

for CTlaser, CSlaser, CTvideo, CSvideo [**Part-No.: ACCJAFPCTL**]

CTlaser, CSlaser, CTvideo, CSvideo

2.2 Accessories

2.2.1 High temperature cable

High temperature Ethernet cable cat.6 (180 °C), 10 m, incl. 2x RJ45 connector
[Part-No.: ACCJAETCB10H]

High temperature Ethernet cable cat.6 (180 °C), 20 m, incl. 2x RJ45 connector
[Part-No.: ACCJAETCB20H]

High temperature Ethernet cable cat.6 (250 °C), 10 m, incl. 2x RJ45 connector
[Part-No.: ACCJAETCB10H2]

High temperature Ethernet cable cat.6 (250 °C), 20 m, incl. 2x RJ45 connector
[Part-No.: ACCJAETCB20H2]

High temperature USB cable (180 °C), 5 m
[Part-No.: ACPIUSB5PCB5H]

High temperature USB cable (180 °C), 10 m
[Part-No.: ACPIUSB5PCB10H]

High temperature USB cable (250 °C), 5 m
[Part-No.: ACPIUSB5PCB5H2]

High temperature USB cable (250 °C), 10 m
[Part-No.: ACPIUSB5PCB10H2]

Pyrometer cable (available separately)

2.2.2 Protection window



Adequate protection windows are available for all versions.

Part-No.	Description	Spectral range	Transmission ¹⁾
ACCJAPWPILW	Protective window (50,8 x 3 mm/ Ge) for PI450 G7, 640 G7	7,9 µm	0.96
ACCJAPWPILW	Protective window (50,8 x 3 mm/ Ge) for PI160, 4xx, 640	7,5-13 µm	0.92
ACCJAPWZNS	Protective window (50,8 x 3 mm/ ZnS) for PI450 G7, 640 G7	7,9 µm	0.93
ACCJAPWZNS	Protective window (50,8 x 3 mm/ ZnS) for PI160, 4xx, 450 G7, 640	7,5-13 µm	0.91
ACCJAPWPI2XXLW	Protective window (67 x 3 mm/ ZnS) for PI2xx (VIS + IR transmittive)	7,5-13 µm	0.91
ACCJAPWCTLSW	Protective window (67 x 3 mm/ Borofloat 33) for 1M/ 2M/ 3M-models of CTlaser-, CSLaser-, CTvideo-, CSvideo series, PI1M, PI05M	1,0/ 1,6/ 2,3 µm 1 µm, 500-540 nm	0.92

¹⁾ The shown values are standard values and may vary between different delivery batches.

2.2.3 Mounting flange

Mounting flange [**Part-No.: ACCJAMF**] for front mounting of the CoolingJacket Advanced (Standard and Extended) including mounting screws and washers

2.2.4 Laminar air purge

Laminar air purge for front mounting of the CoolingJacket Advanced (Standard and Extended). Two different versions are available: One for standard IR camera applications [**Part-No.: ACCJAAPLS**] and the other for line scanning applications [**Part-No.: ACCJAAPLL**].

Those two versions are fitting to all focusing units with production date $\geq 01/2018$. A protective window (67 x 3 mm) has to be ordered separately. If you like to mount the air purge on an older CJ, the focusing unit should be exchanged to the current version

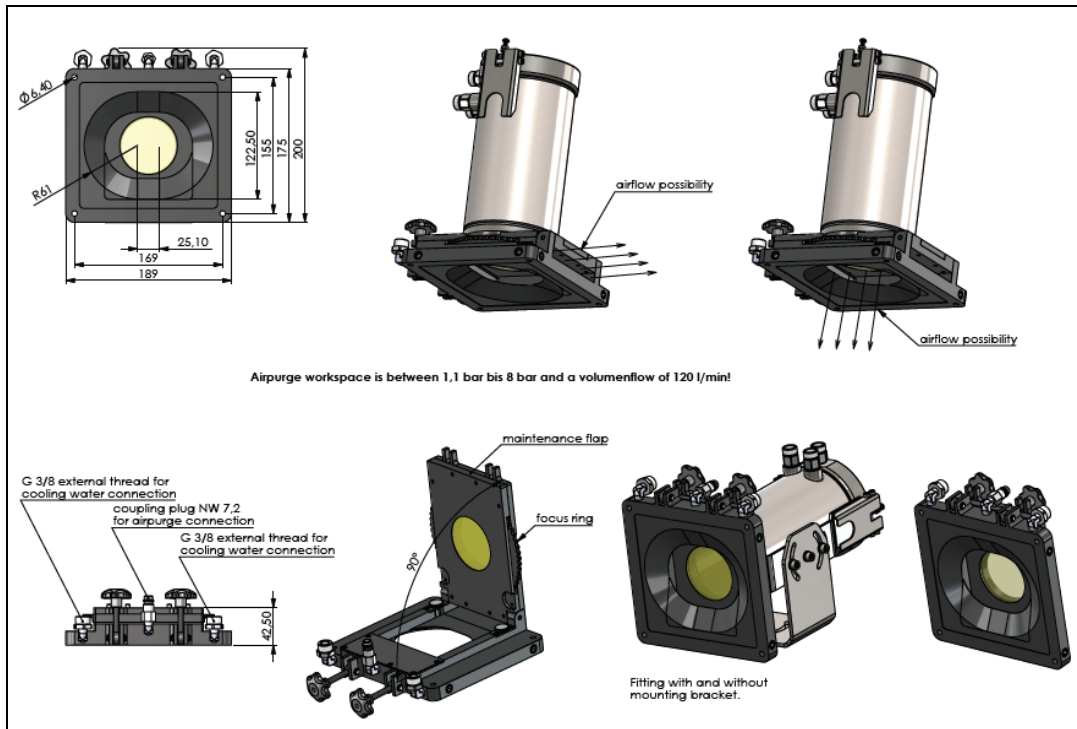

Figure 3: Dimensions of laminar air purge

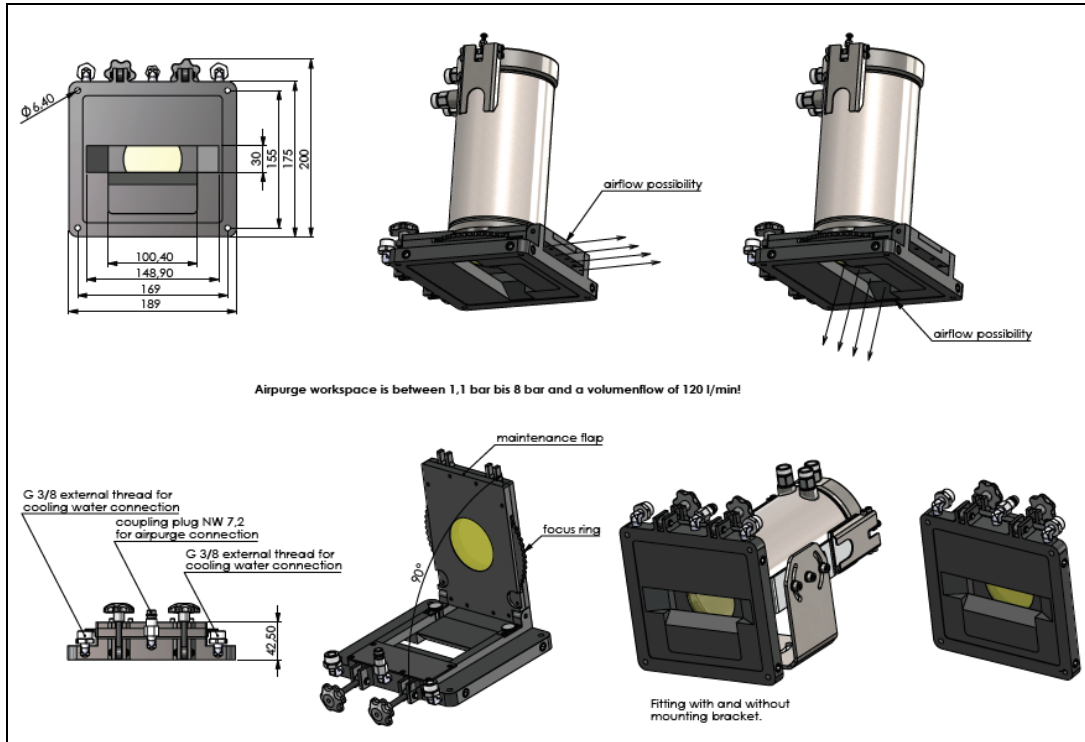

Figure 4: Dimensions of laminar air purge (line scanner version)

2.2.5 Additional accessories

Industrial PIF without housing [**Part-No.: ACCJAPIPIF500V2**], 500 VAC_{RMS} isolation voltage between PI and process, 25 cm connection cable

2.3 Dimensions

Standard version

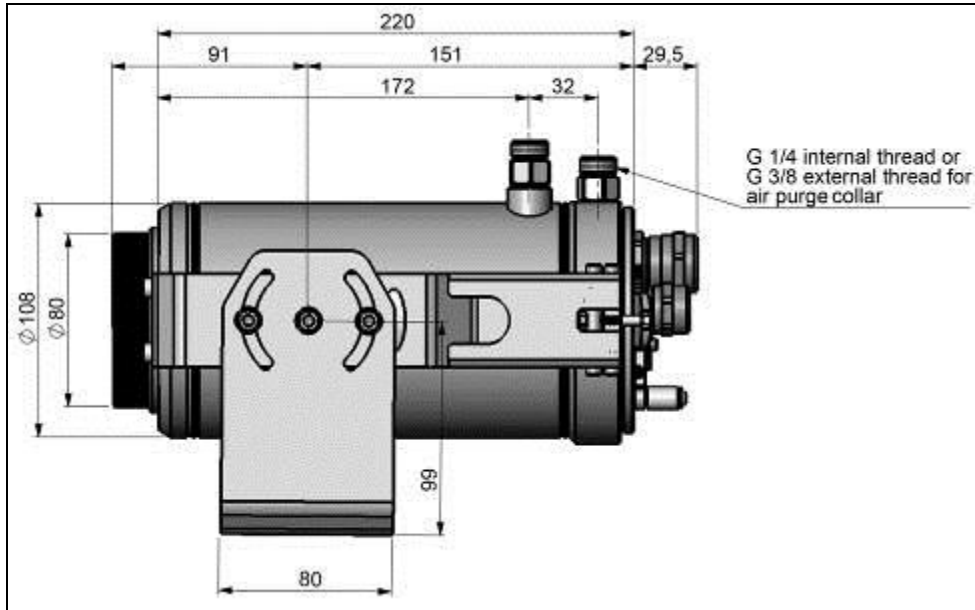

Figure 5: CoolingJacket Advanced, standard version – side view

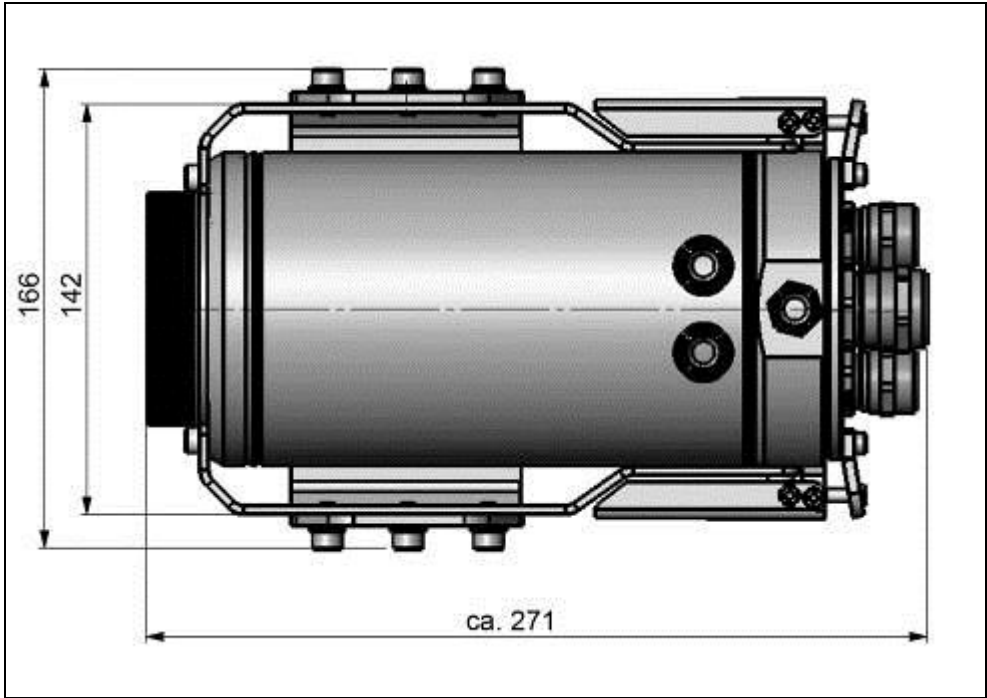

Figure 6: CoolingJacket Advanced, standard version – top view

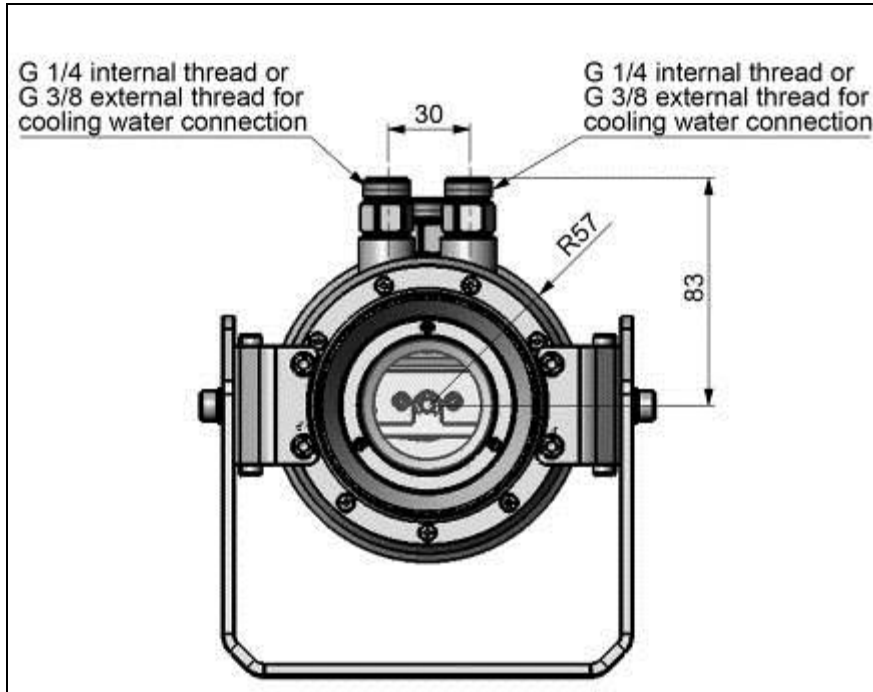

Figure 7: CoolingJacket Advanced, standard version – front view

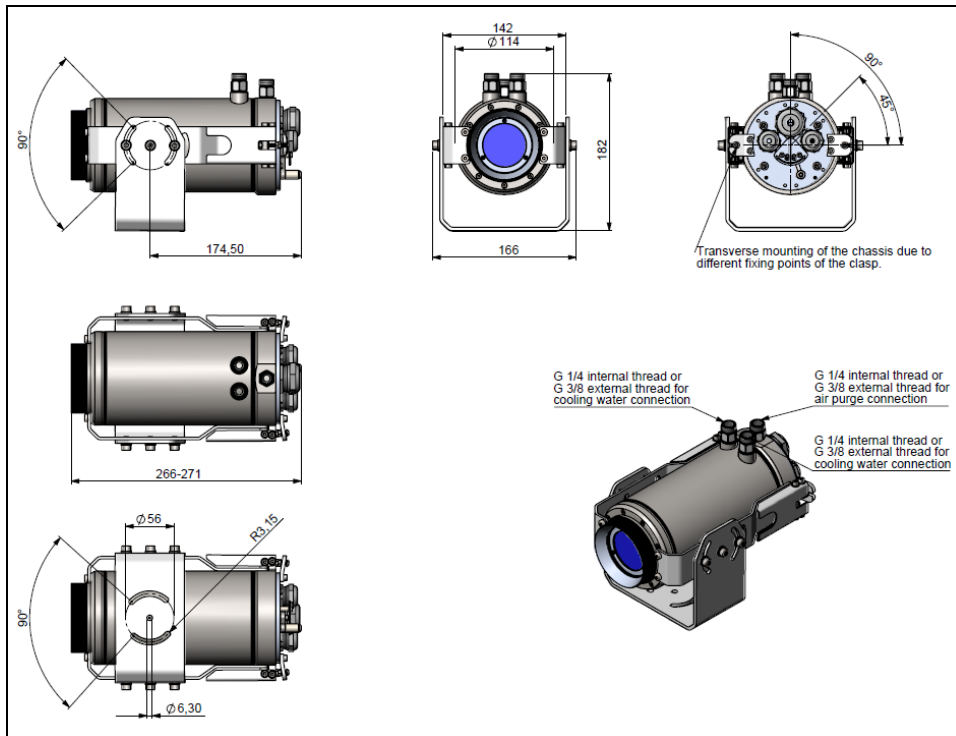
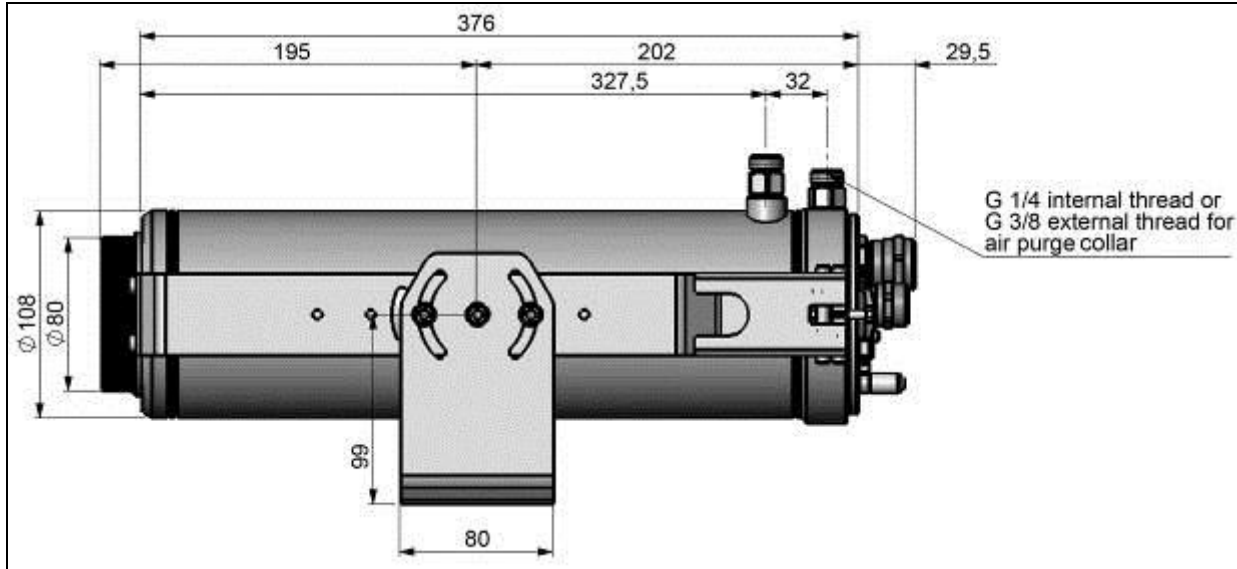

Figure 8: CoolingJacket Advanced, standard version – complete view

Extended version**Figure 9:** CoolingJacket Advanced, extended version – side view

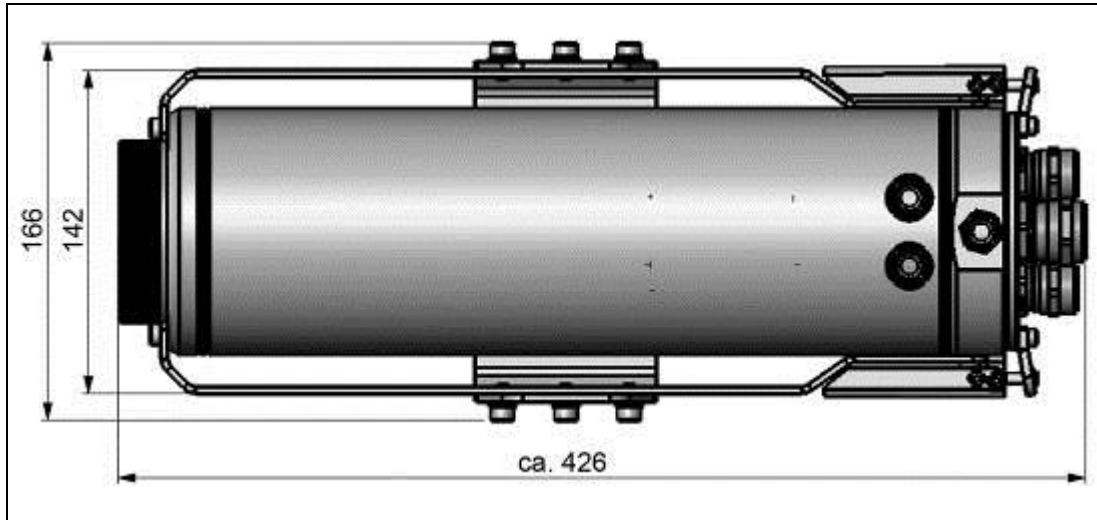

Figure 10: CoolingJacket Advanced, extended version – top view

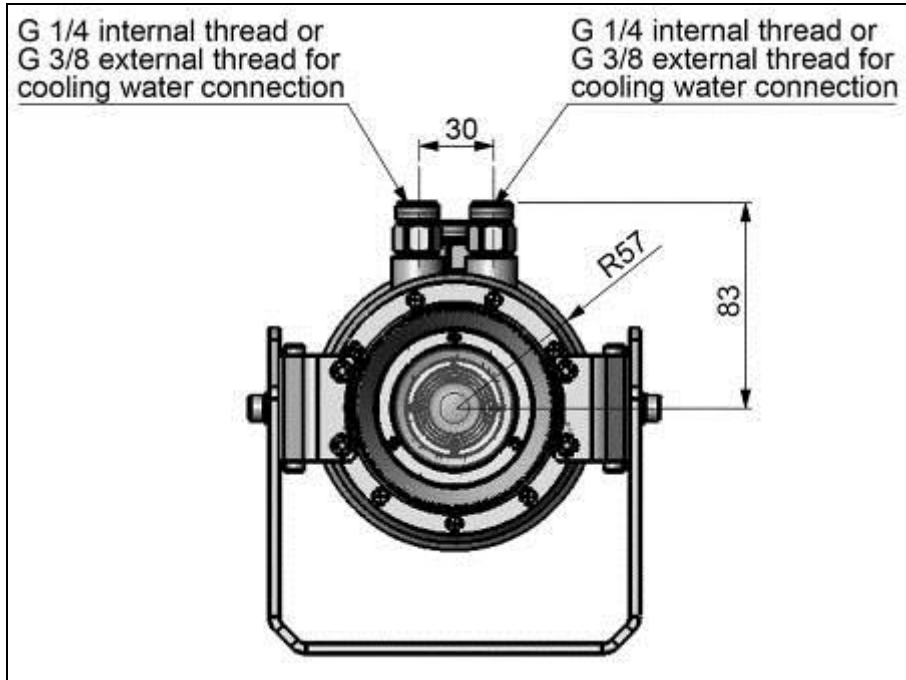

Figure 11: CoolingJacket Advanced, extended version – front view

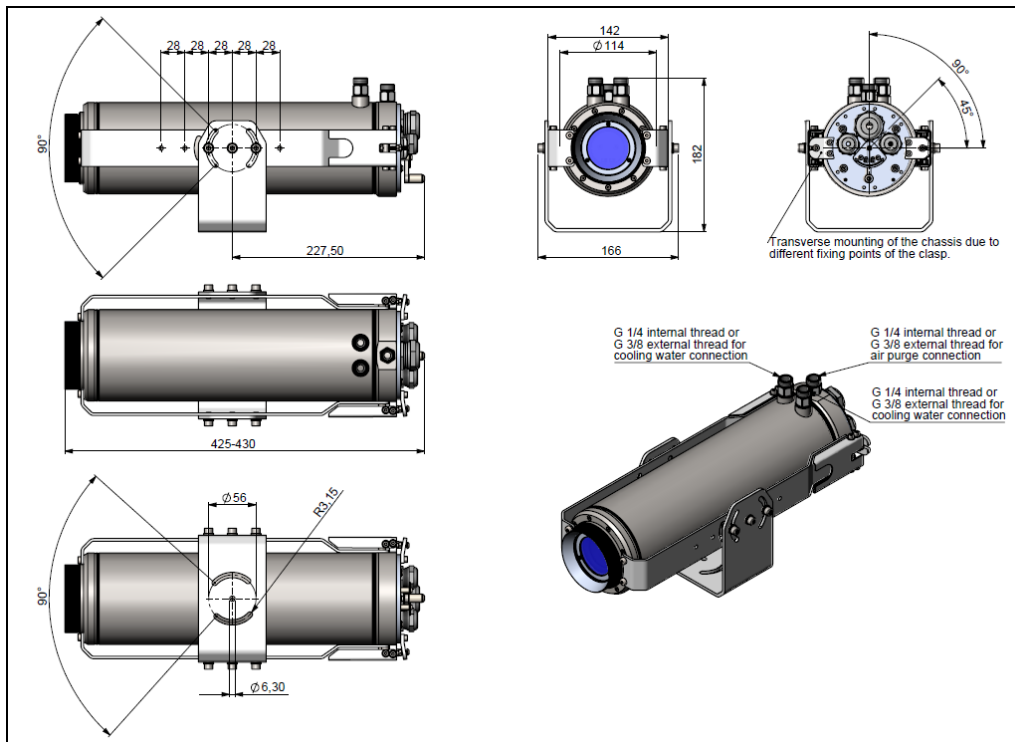

Figure 12: CoolingJacket Advanced, extended version – complete view

Mounting flange (Accessories)

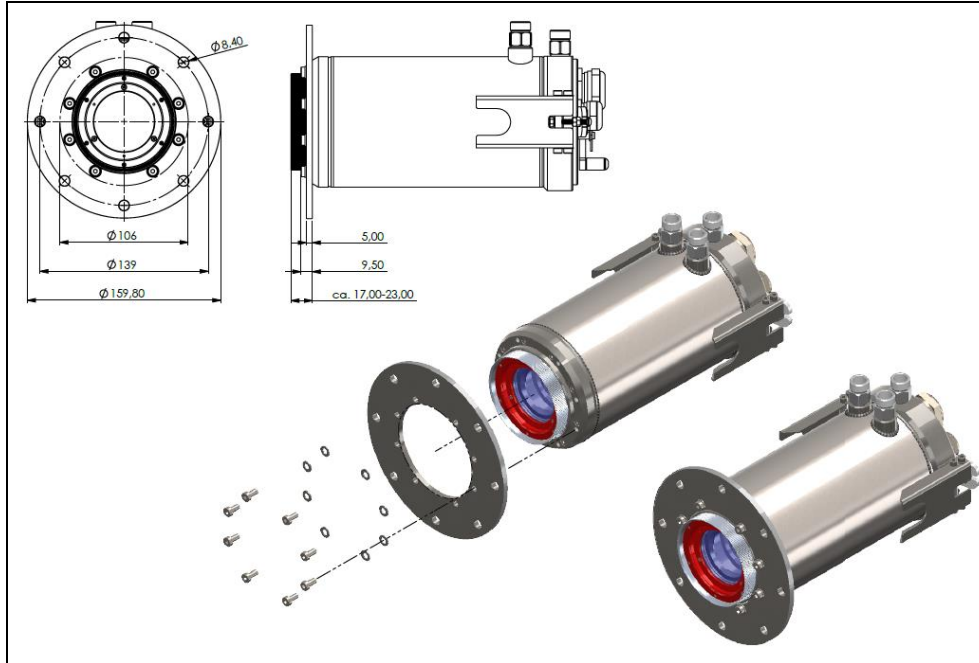

Figure 13: Mounting flange for CoolingJacket Advanced (Standard and Extended)

2.4 Fittings

2.4.1 Cooling water fitting



- The cooling water input and output has a G1/4"-internal thread and a G3/8"-external thread.
- The maximum cooling water pressure is 15 bar (271 psi).
- While connecting the hoses keep inclined the Cooling Jacket at an angle of approx. 45° to avoid air bubbles.

2.4.2 Air purge collar



- Use oil-free, technically clean air only.
- The needed amount of air (at least 120 l/ min., 5-8 bar) depends on the application and the installation conditions on-site.
- The air purge collar has a G1/4"-internal thread and a G3/8"-external thread.

The lens must be kept clean at all times from dust, smoke, fumes and other contaminants in order to avoid reading errors. These effects can be reduced by using an air purge collar.

The following classes according to ISO 8573-1 are recommended for the quality of compressed air:

	Classes
Oil content:	class 2 or better
Water content:	class 4 or better
Solid content:	class 2 or better

2.4.3 Cable glands on the back

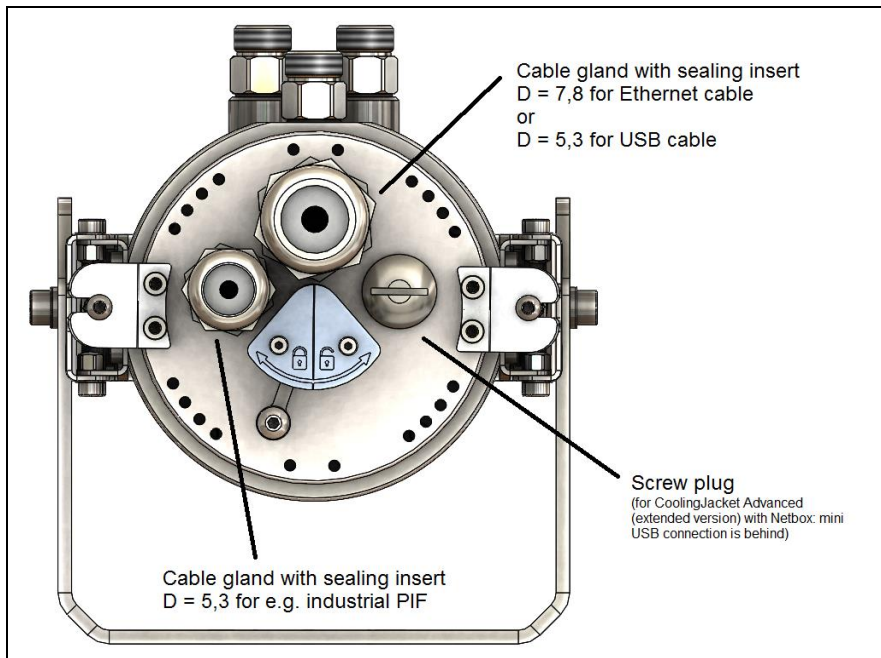

Figure 14: Cable glands with seal insert

2.5 Cooling properties

Flow		Temperature at 1 l/min	Temperature at 2,5 l/min	Temperature at 5 l/min
Ambient temperature [255 °C]	Cooling water input [°C]	19	19	19
	Camera/ Thermometer [°C]	36	34	32

Table 1: Cooling properties with a steady cooling water input temperature and various flow

Flow		Temperature at 2.5 l/min of flow			
Ambient temperature [255 °C]	Cooling water input [°C]	25	30	35	40
	Camera/ Thermometer [°C]	39	42	45	51

Table 2: Cooling properties with a steady flow and various cooling water input temperature

2.5.1 Condensation



- For applications at ambient temperatures until 100 °C and a high humidity there is danger of condensation (see **Table 3**).
- To avoid condensation, the temperature of the cooling media and the flow rate must ensure a minimum device temperature.
- Consider the operation temperature of the applied devices.

Example (see **Table 3**):

Ambient temperature	80 °C
Relative humidity	25 %
Minimum device temperature	45 °C

At an ambient temperature of 80 °C and a relative humidity of 25 % the device temperature must not be below 45 °C. Otherwise condensation occurs on the lens or the electronic.

		Relative humidity [%]																		
		10	15	20	<u>25</u>	30	35	40	45	50	55	60	65	70	75	80	85	90	95	100
Ambient temperature [°C]	0	0	0	0	0	0	0	0	0	0	0	0	0	0	0	0	0	0	0	0
	5	0	0	0	0	0	0	0	0	0	0	0	0	0	0	0	0	0	0	5
	10	0	0	0	0	0	0	0	0	0	0	0	0	0	5	5	5	5	5	10
	15	0	0	0	0	0	0	0	0	0	5	5	5	5	10	10	10	10	10	15
	20	0	0	0	0	0	0	5	5	5	10	10	10	10	15	15	15	15	15	20
	25	0	0	0	0	5	5	10	10	10	10	15	15	15	20	20	20	20	20	25
	30	0	0	0	5	5	10	10	15	15	15	20	20	20	20	25	25	25	25	30
	35	0	0	5	10	10	15	15	20	20	20	25	25	25	25	30	30	30	30	35
	40	0	5	10	10	15	20	20	20	25	25	25	30	30	30	35	35	35	35	40
	45	0	10	15	15	20	25	25	25	30	30	35	35	35	35	40	40	40	40	45
	50	5	10	15	20	25	25	30	30	35	35	35	40	40	40	453	45	45	45	50
	60	15	20	25	30	30	35	40	40	40	45	45	50	50	50	50	50	50	50	60
	70	20	25	35	35	40	45	45	50	50	50	50	50	60	60	60	60	60	60	70
	<u>80</u>	25	35	40	<u>45</u>	50	50	50	60	60	60	60	60	70	70	70	70	70	70	80
	90	35	40	50	50	50	60	60	60	70	70	70	70	80	80	80	80	80	80	
	100	40	50	50	60	60	70	70	70	80	80	80	80	80						

Table 3: Minimum device temperature in relation to ambient temperature and relative humidity in [°C]

3 Installation

3.1 Installation

The CoolingJacket Advanced both in the standard version and in the extended version can be installed in the desired position via the mounting bracket.

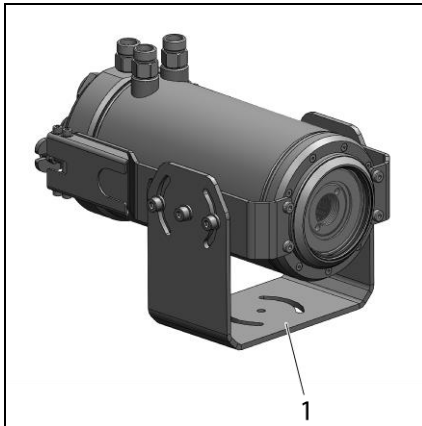

Figure 15: CoolingJacket Advanced with mounting bracket

- 1 Mounting bracket, adjustable in two axes

3.2 Installation of PI camera, infrared video thermometer and infrared thermometer

3.2.1 Assembling of the focusing unit



The focusing unit consists of two parts, external **(1)** and internal **(2)** part. The external part focuses the camera. The internal part fixes the camera.



Figure 16: Focusing unit (external and internal part)

- 1 External part of the focusing unit
- 2 Internal part of the focusing unit

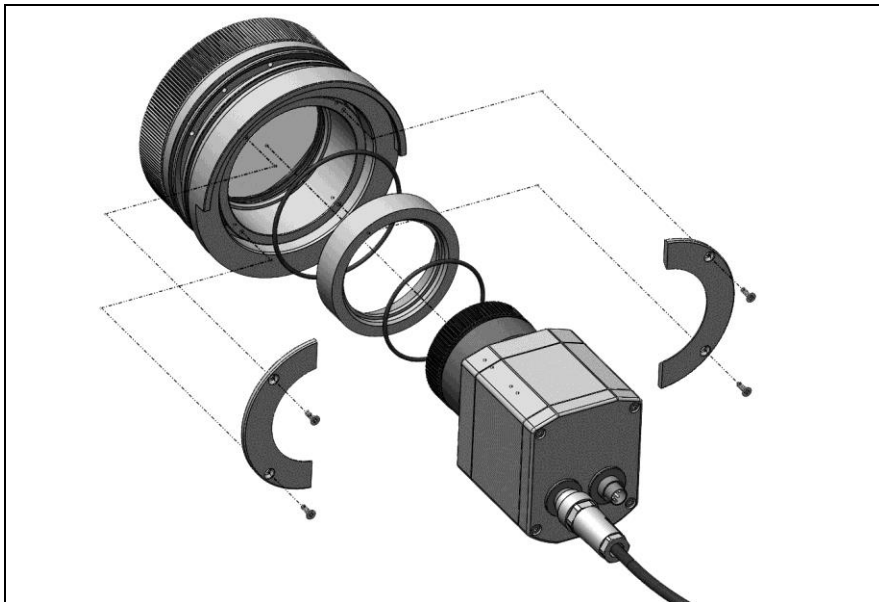

Figure 17: Assembling of the 6°, 9°, 23°, 26°, 29°, 33°, 39°, 41°, 53°, 72° and 80° optics

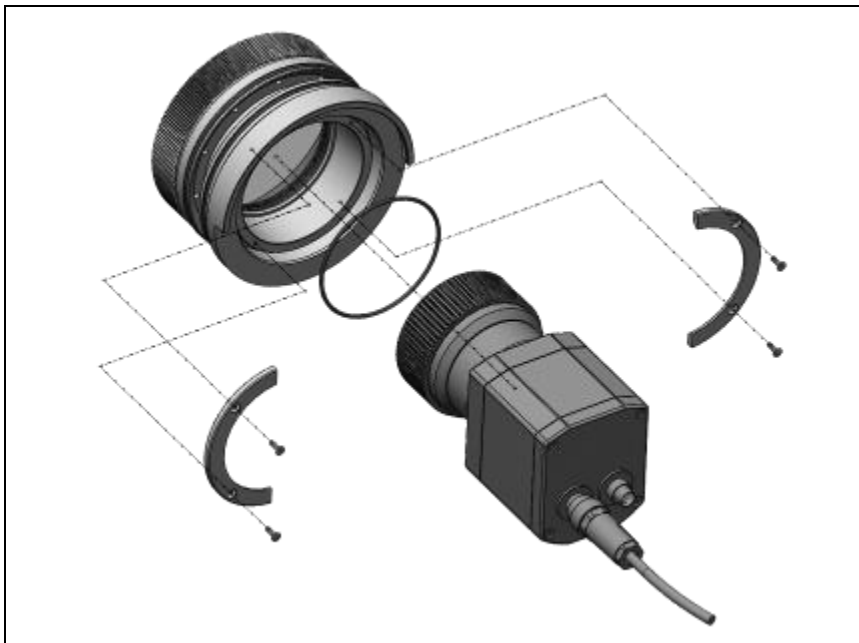

Figure 18: Assembling of the 13° and 15° optics

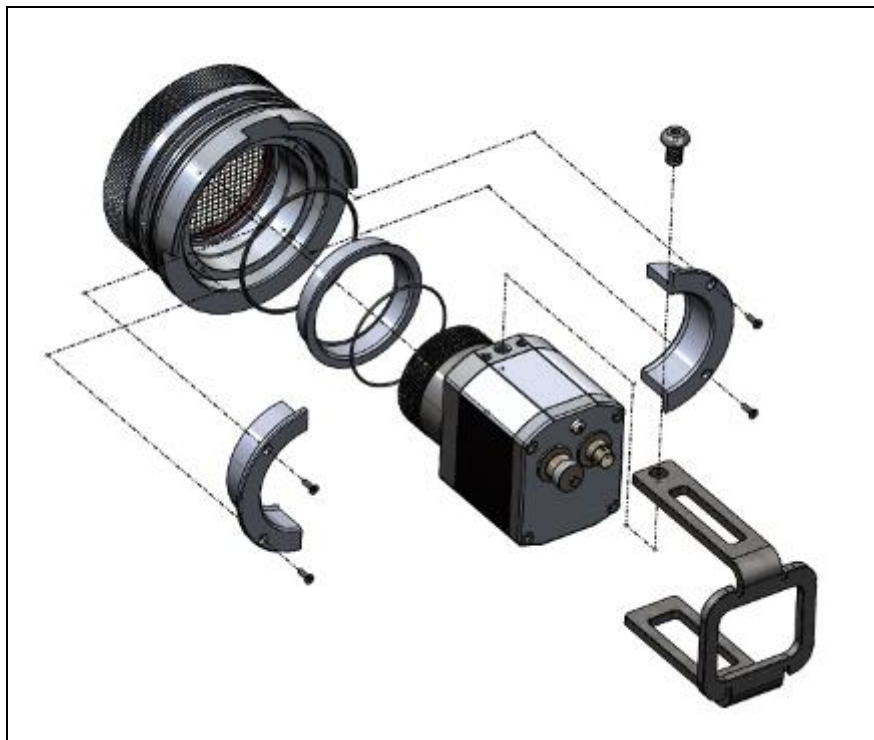

Figure 19: Assembling of the 60° and 90° optics

3.2.2 Assembling of the front part

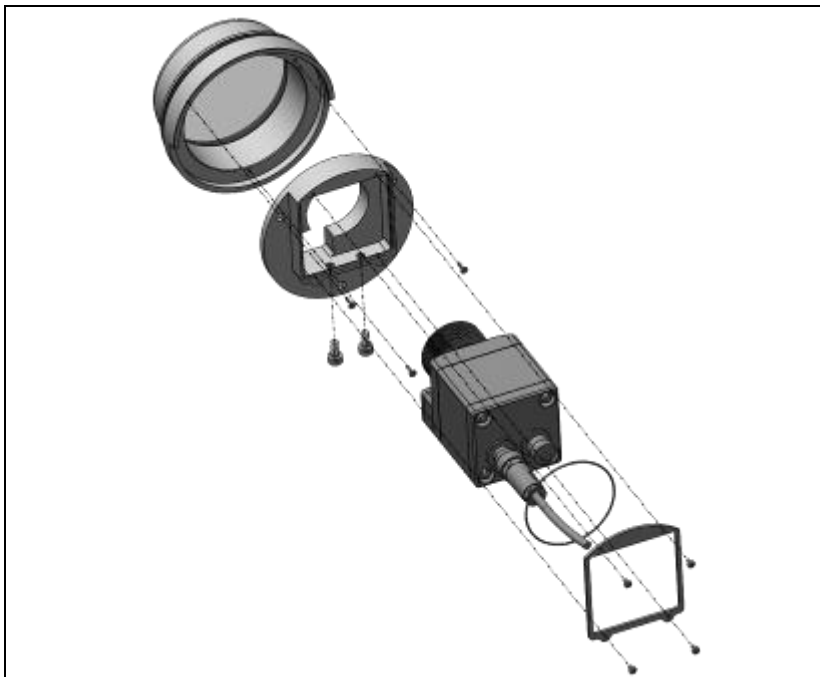

Figure 20: Assembling of the PI 2xx

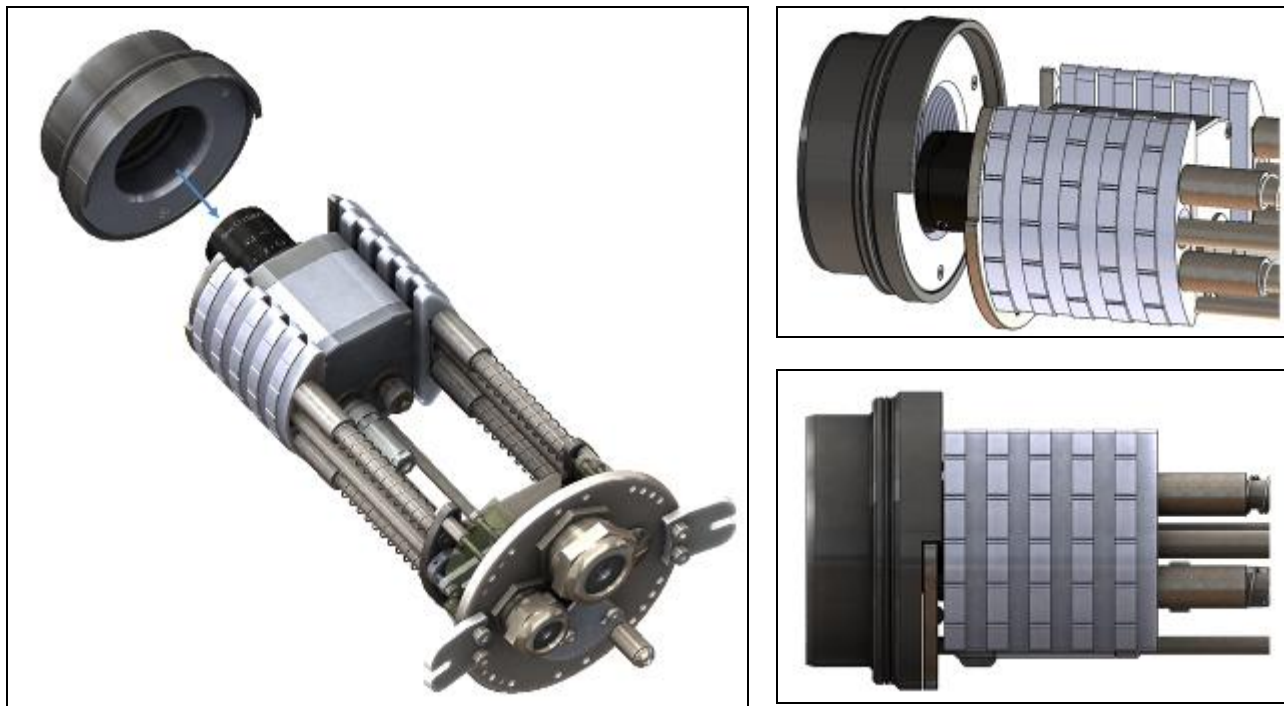

Figure 21: Assembling of the PI 1M/ 05M

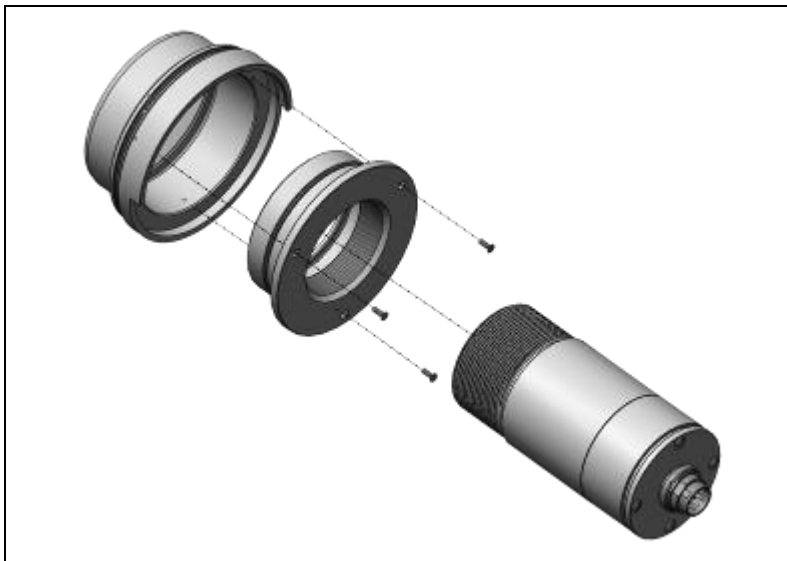

Figure 22: Assembling of the CTlaser, CSLaser, CTvideo, CSvideo

3.2.3 Mounting of protective window at focusing unit

- Step 1:** Loosen the three countersunk head screws M2 x 5 (inside) and remove them!
- Step 2:** Turn six countersunk head screws M1.6 x 4 (outside) by two turns to the left! (**Do not unscrew or remove!**)
- Step 3:** Now carefully pull the nozzle ring out of the focusing unit!
- Step 4:** Place the protective window in the provided platform of the focusing unit and the O-ring 50 x 1.5 in the provided nut of the nozzle ring!
- Step 5:** Plug the nozzle ring back into the focusing unit and secure it with the three countersunk head screws M2 x 5 (inside)!
- Step 6:** Now tighten the six countersunk head screws M1.6 x 4 (outside) by twisting them two turns to the right!

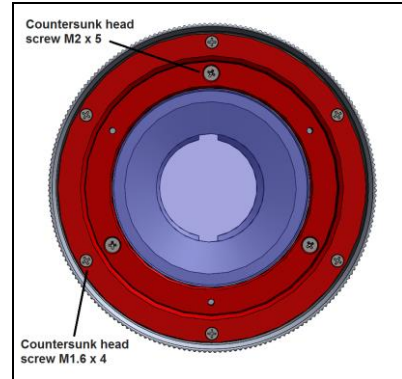

Figure 23: Focusing unit

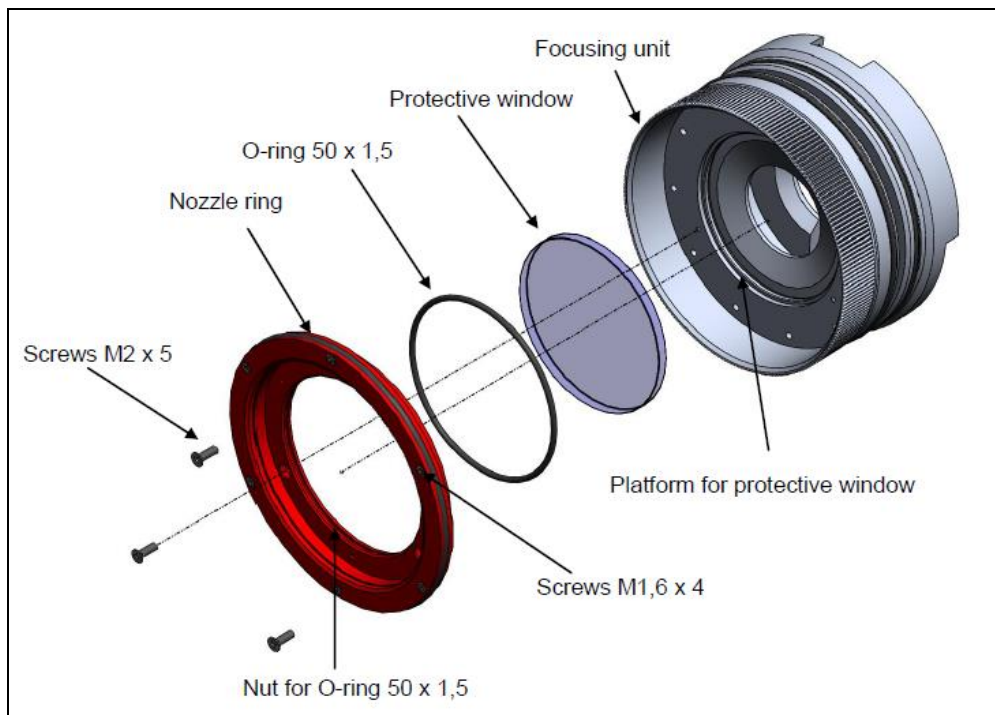

Figure 24: Individual components of the focusing unit

3.2.4 Assembly of the laminar air purge

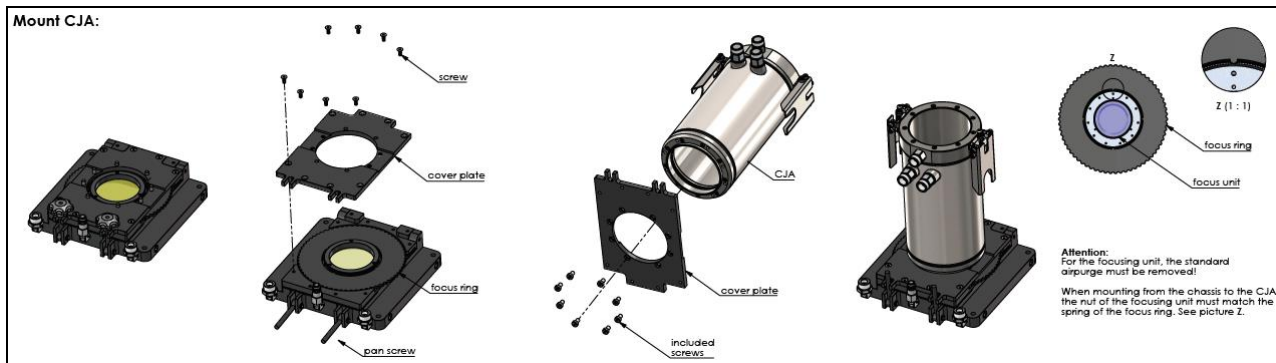

Figure 25: Assembly of the laminar air purge

Adjust air outflow direction:

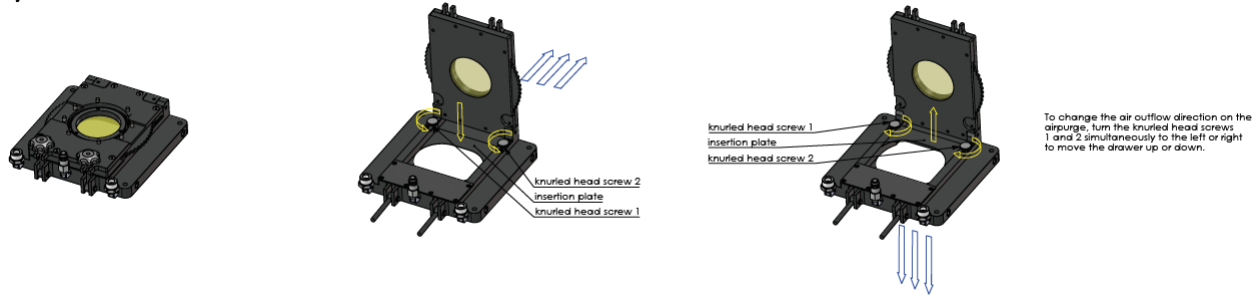

Figure 26: Adjustment of air outflow

Change protective window:

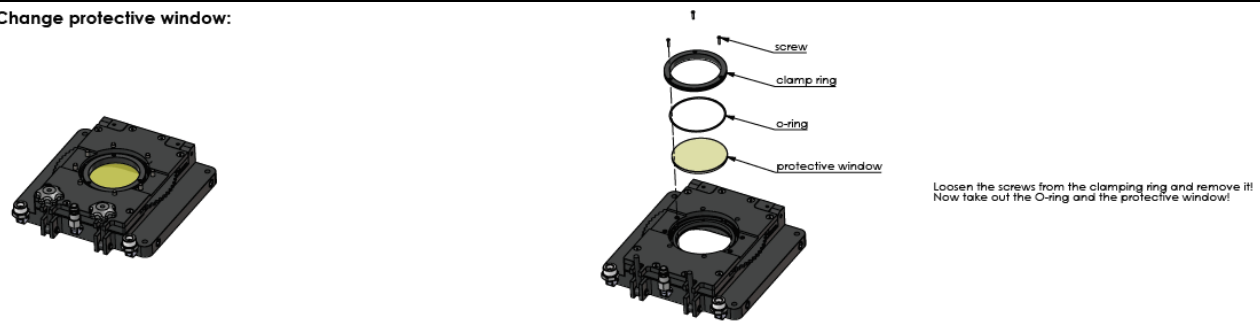

Figure 27: Change of the protective window

3.2.5 Assembling to the standard version

Depending on the chassis either a camera of the PI series, a laser infrared thermometer or an infrared video thermometer can be installed.

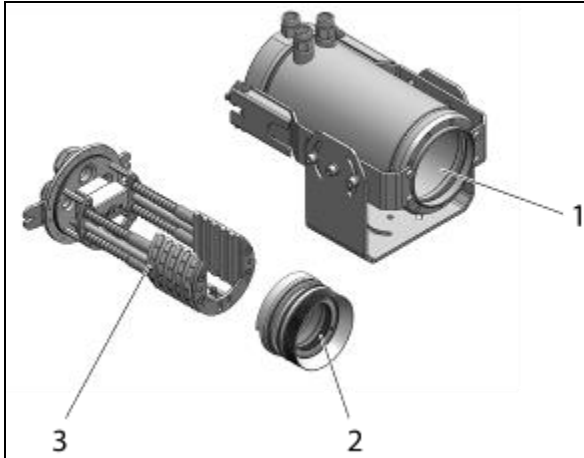

Figure 28: CoolingJacket Advanced, standard version

- 1 Housing
- 2 Front part (or focusing unit)
- 3 Chassis

Installation of PI camera

1. Mount the camera to the focusing unit or the front part as described in **chapter 3.2.1** respectively **chapter 3.2.2** (except for PI 1M/ 05M camera).
2. Seat the focusing unit or front part in the chassis (**Figure 29**). Pay attention to the correct positioning of the two bars at the bottom of the chassis. These must be moved in the slot for the respective camera used (**Figure 30, Figure 31**). Position it as shown in **Figure 32**, by pushing it to the bottom. The PI 1M/ 05M camera is first placed into the chassis without the front part. After that the front part is attached to the optic. Make sure that the front part is placed at a height of approx. 5 mm above the optic in order to be able to slide it over the chassis front plate (**Figure 21**).

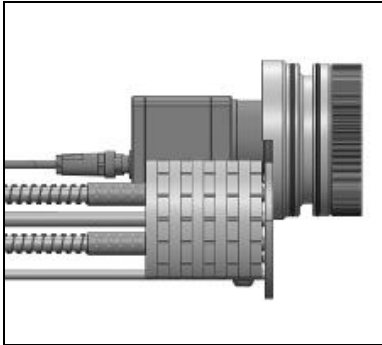

Figure 29: Inserting of the focusing unit

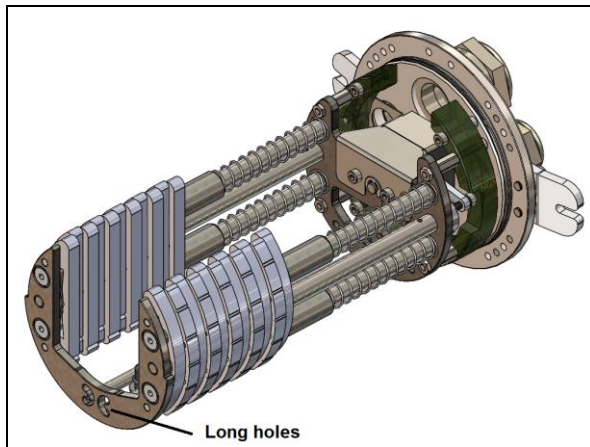

Figure 30: Long holes on the bottom of the chassis

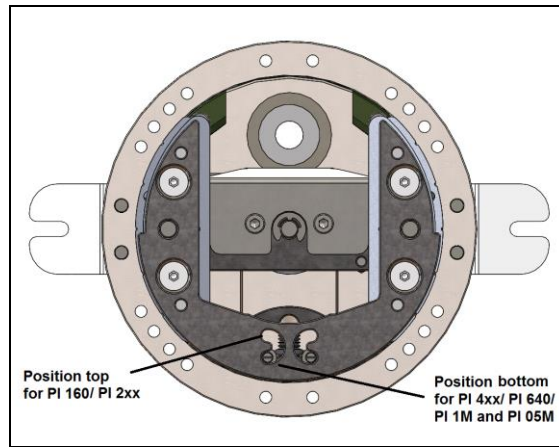

Figure 31: Positioning the two bars in the slot for different cameras

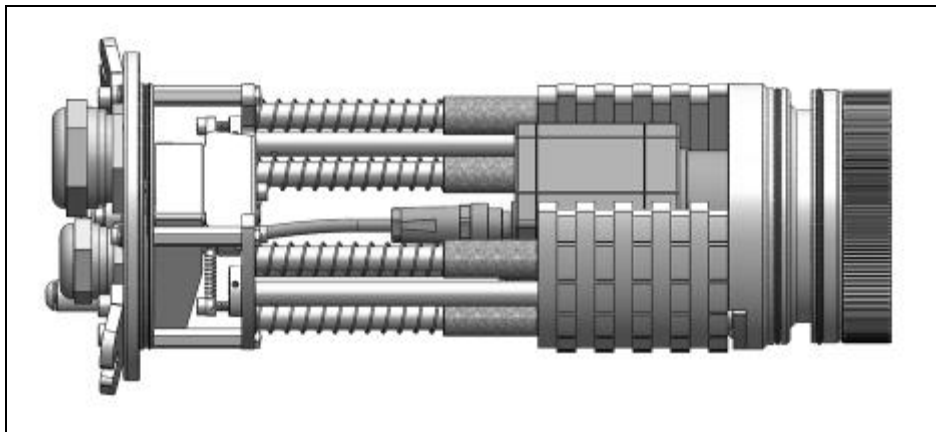

Figure 32: Focusing unit with camera

3. Fix the camera with the provided screw on the bottom of the chassis.

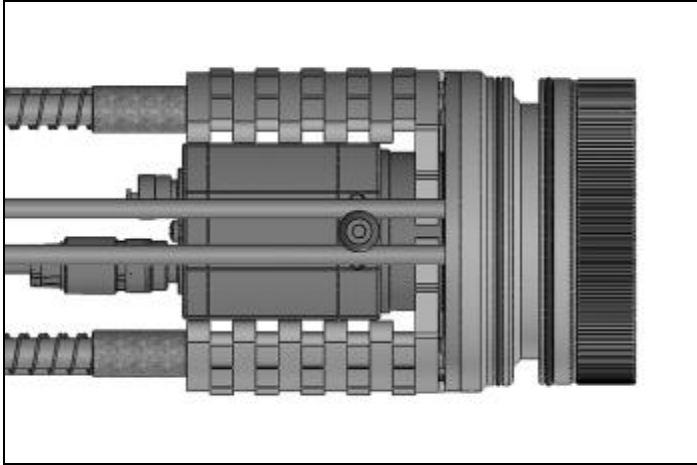

Figure 33: Mounting of the camera to the chassis

4. Then connect the PI camera with the provided USB cable and lead it out of the cable gland.
5. Slide the chassis with the camera in the housing. Put the pins of the hinges to the slits of the chassis and lock the hinge by pushing it forward (**Figure 34**).

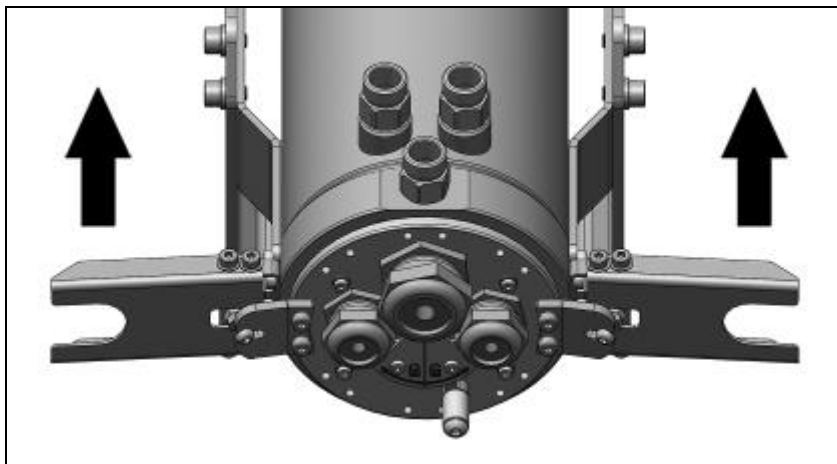

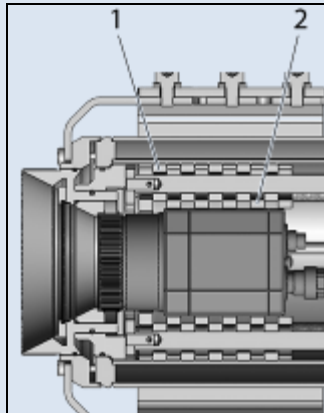

Figure 34: Locking of the hinge

6. Move the locking lever to the left (symbol: ) , so that the chassis is fitted close to the inner surface of the housing (**Figure 35**).

The alternate contact of the cooling jaws with the camera/ infrared thermometer and inner housing generates an optimal cooling effect.



- 1 Contact of the cooling jaws and inner housing
- 2 Contact of the cooling jaws and camera/ infrared thermometer

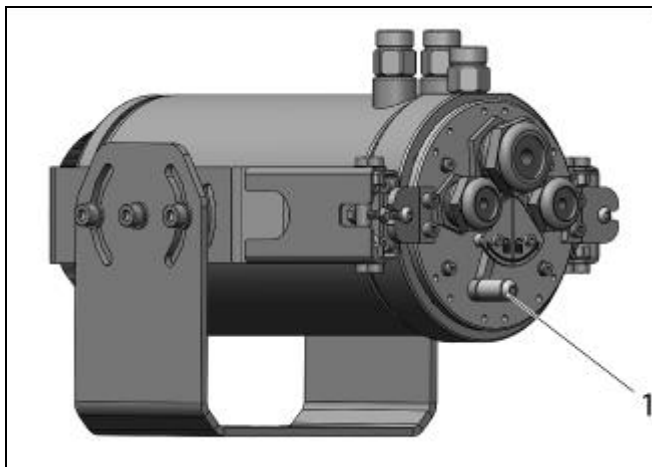

Figure 35: Back side of the CoolingJacket with locking lever

- 1 Locking lever

7. Dismount in reverse order.

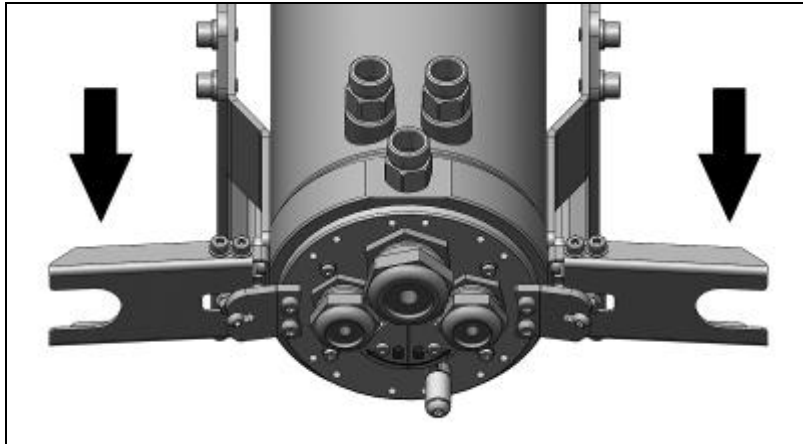

Figure 36: Unlocking of the hinge

Installation of video thermometer or infrared thermometer

1. Screw the infrared thermometer in the thread (M48x1.5) of the front part (see **Figure 22**) and seat the front part in the chassis (**Figure 37**).



Figure 37: Front part with infrared thermometer

2. Lead the sensor cable out of the cable gland.

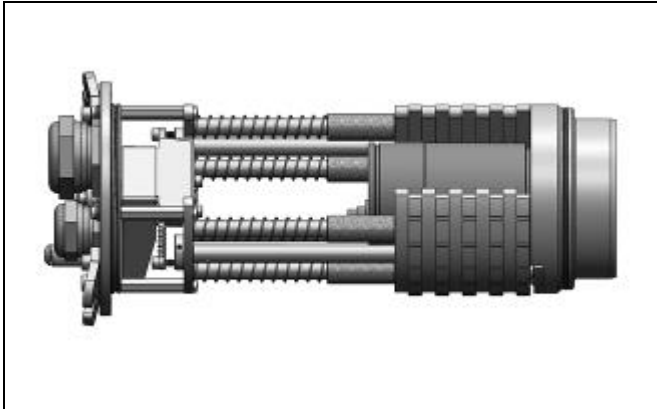



Figure 38: Infrared thermometer mounted

3. Slide the chassis with the camera in the housing. Put the pins of the hinges to the slits of the chassis and lock the hinge by pushing in forward (**Figure 34**).
4. Move the locking lever to the left (symbol: ) , so that the chassis is fitted close to the inner surface of the housing (**Figure 35**)
5. Dismount in reverse order (**Figure 36**).

3.2.6 Assembling to the extended version

The extended version of the CoolingJacket Advanced provides an installation of the PI series together with the PI Netbox and an industrial PIF or with the USB server Gigabit and an industrial PIF.

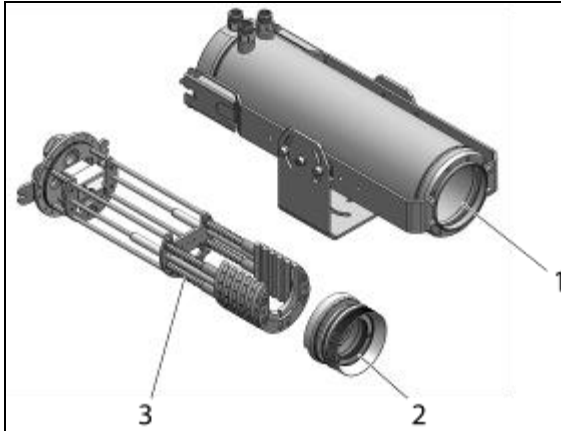

Figure 39: CoolingJacket Advanced, extended version

- 1 Housing
- 2 Focusing unit
- 3 Chassis

Installation of PI camera

Steps 1-3, see page 48.

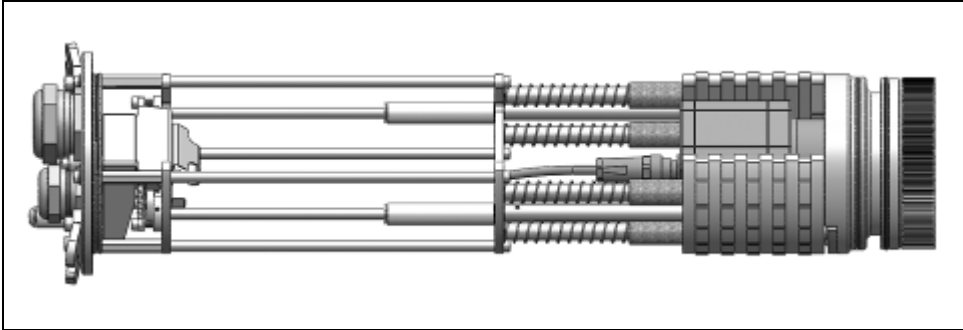

Figure 40: Camera implemented (extended version)

Assembling of PI Netbox and industrial PIF

4. Mount the holding plate (screws M3x5). Then attach the two support rods complete with the distance bolts (SW 5,5x6 - M3x6) with the provided screws (M3x10) to the bottom of the chassis. At last mount the shaft to fix the PI Netbox (**Figure 41**).

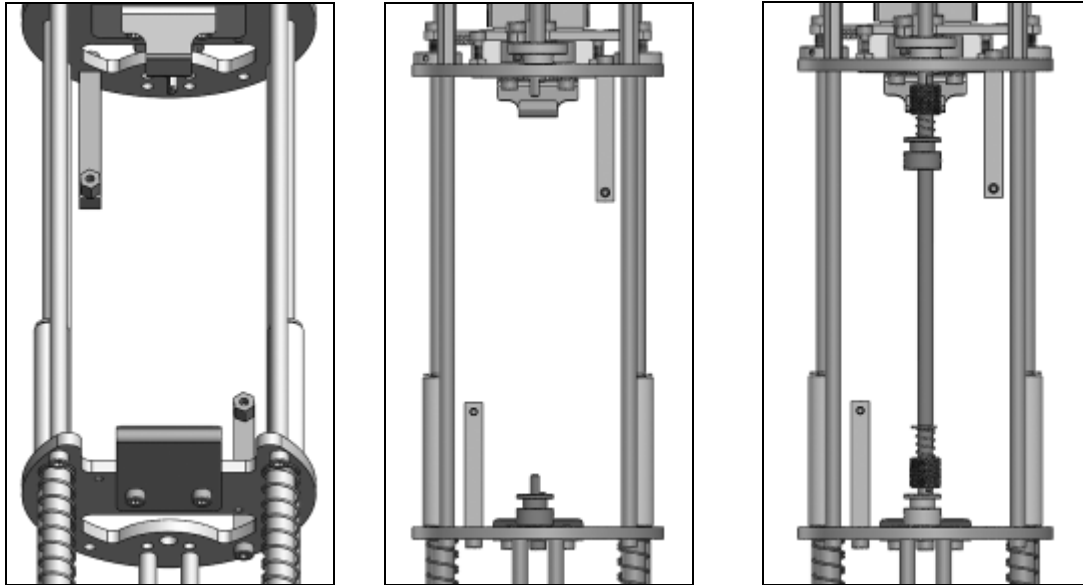

Figure 41 (a-c): Mounting of the accessories for PI Netbox: **a)** Holding plate for PI Netbox (top view), **b)** Support rods for industrial PIF (view from the bottom), **c)** Shaft to fix the PI Netbox (view from the bottom)

5. Fix the industrial PIF with the screws (M3x5) as shown in **Figure 42**.

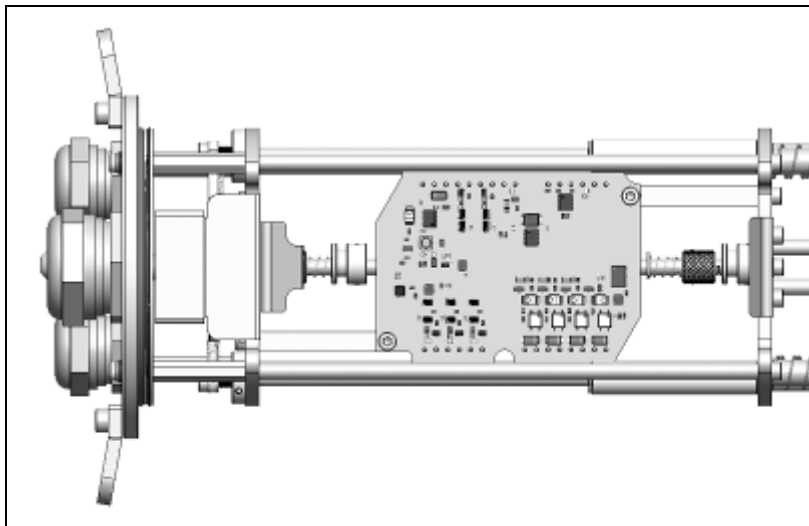

Figure 42: Mounting of the industrial PIF (top view)

6. To mount the PI Netbox to the chassis screw it to the fastening rail (screws M4x8).

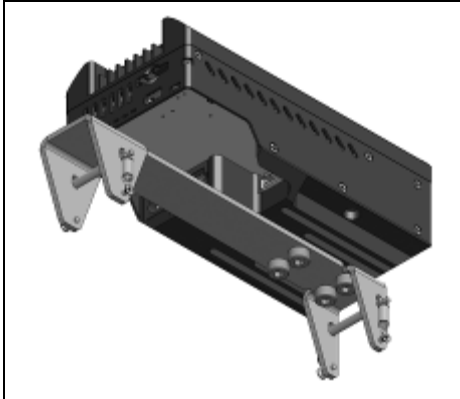

Figure 43: PI Netbox with fastening rail

At first push the fastening rail with the PI Netbox into the left notch (1) of the shaft. Afterwards into the right notch (1) (**Figure 44**) until it is engaged (**Figure 45**).



By locking the chassis the shaft pushes the PI Netbox to the inner surface of the housing. This guarantees an optimal cooling of the PI Netbox.

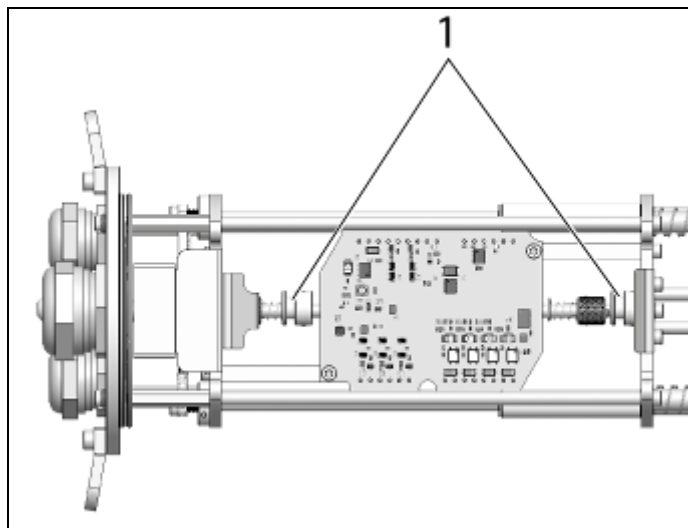

Figure 44: Notch to fix the PI Netbox (top view)

- 1 Notch

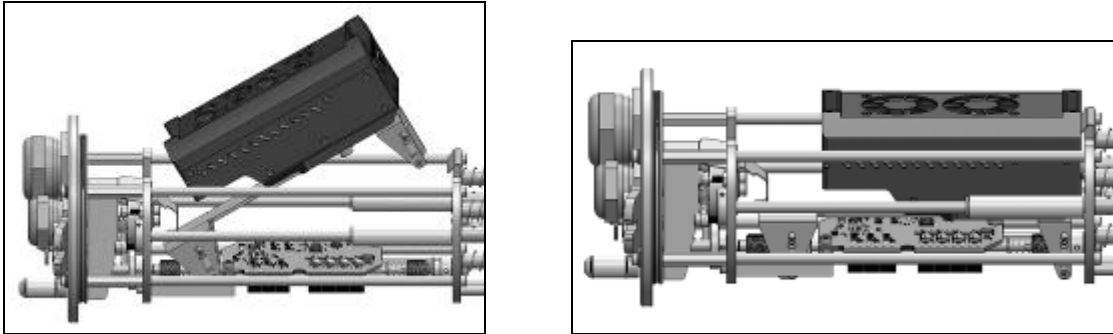

Figure 45: Fitting the PI Netbox into the chassis (right hand view)

7. Then connect the PI camera and the PI Netbox with the provided USB cable and the Industrial PIF with the camera. Combine the network connector and the PI Netbox (**Figure 46**).

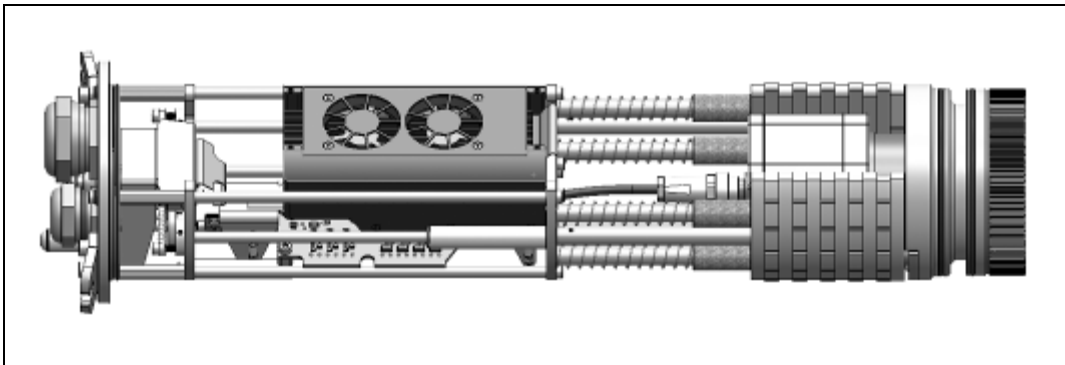

Figure 46: Chassis with PI camera, industrial PIF and PI Netbox

Follow as step 5, **page 51**.

Assembling of USB server Gigabit and Industrial PIF

4. Mount the DIN rail plate with the screws (M3x5) to fix the USB server Gigabit. Then attach the support rods with the provided screws (M3x10) to one side of the chassis; use the distance ring on the left (**Figure 47**).

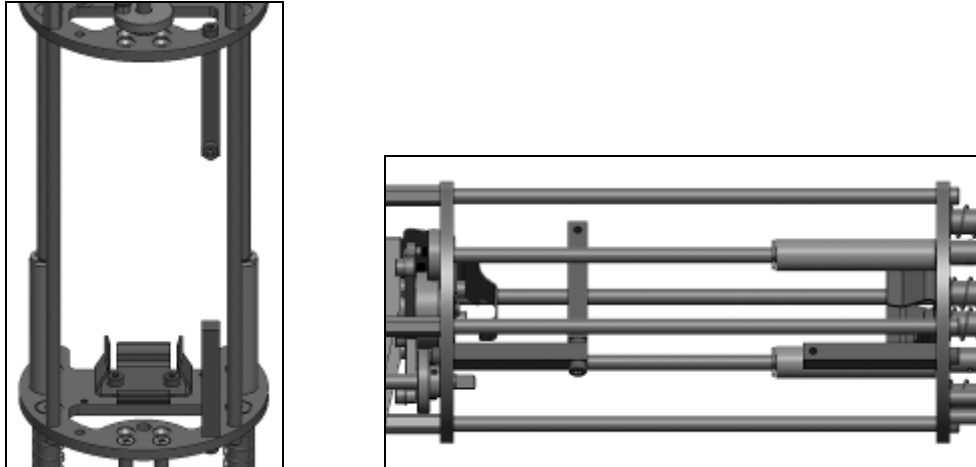

Figure 47 (a + b): Mounting of the accessories for USB server Gigabit: **a)** DIN rail plate for USB server Gigabit (view from the bottom), **b)** Support rods for industrial PIF (right hand view)

5. Fix the Industrial PIF with the screws (M3x5) as shown in **Figure 48**.

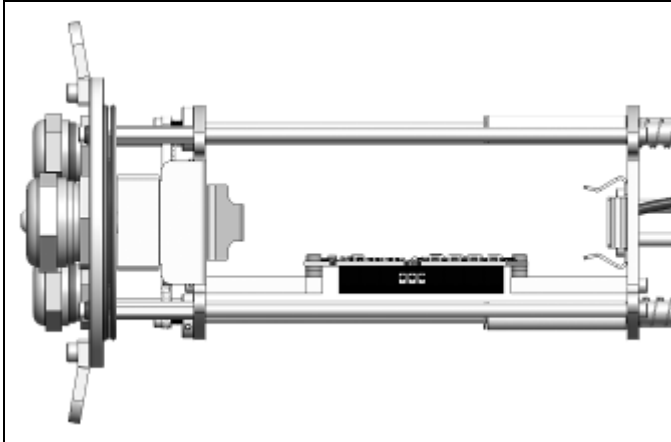

Figure 48: Mounting of the industrial PIF (top view)

6. Engage the USB server Gigabit to the DIN rail plate (**Figure 49**).

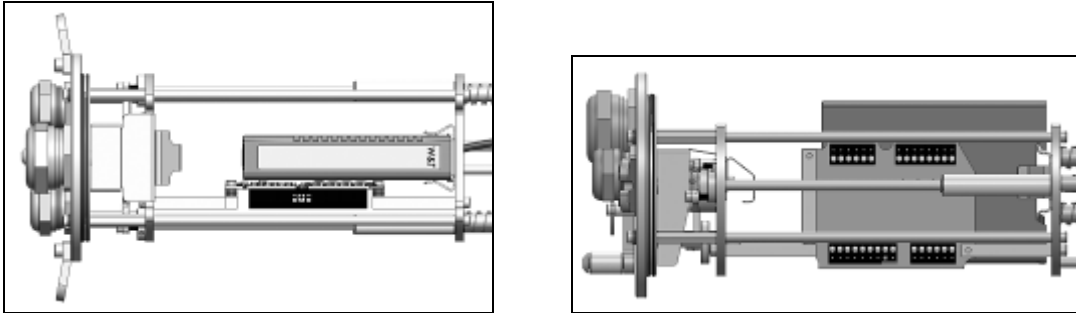

Figure 49 (a + b): Fitting the USB server Gigabit into the chassis (top view and right hand view)

7. Then connect the PI camera and the USB server Gigabit with the provided USB cable and the Industrial PIF with the camera. Combine the network connector and the USB server Gigabit (**Figure 50**).

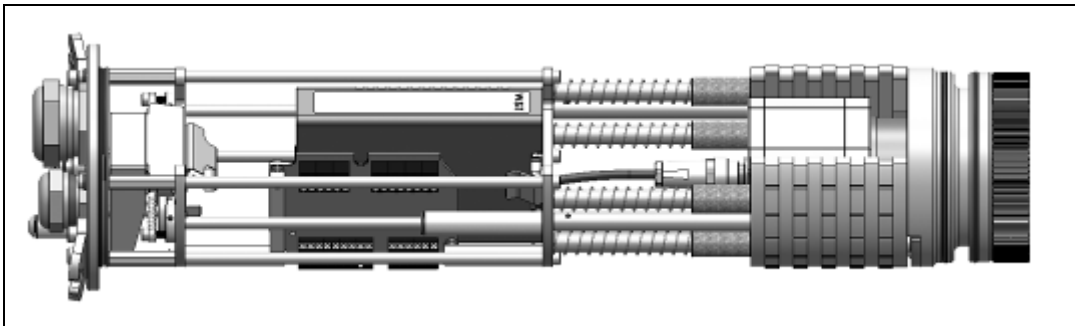
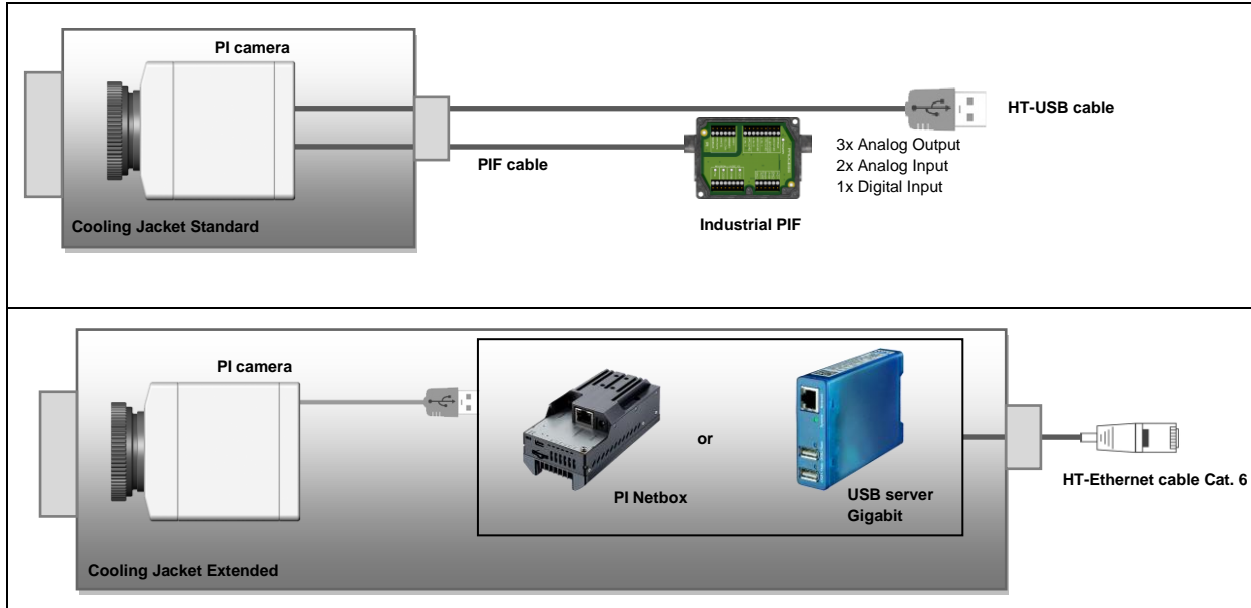
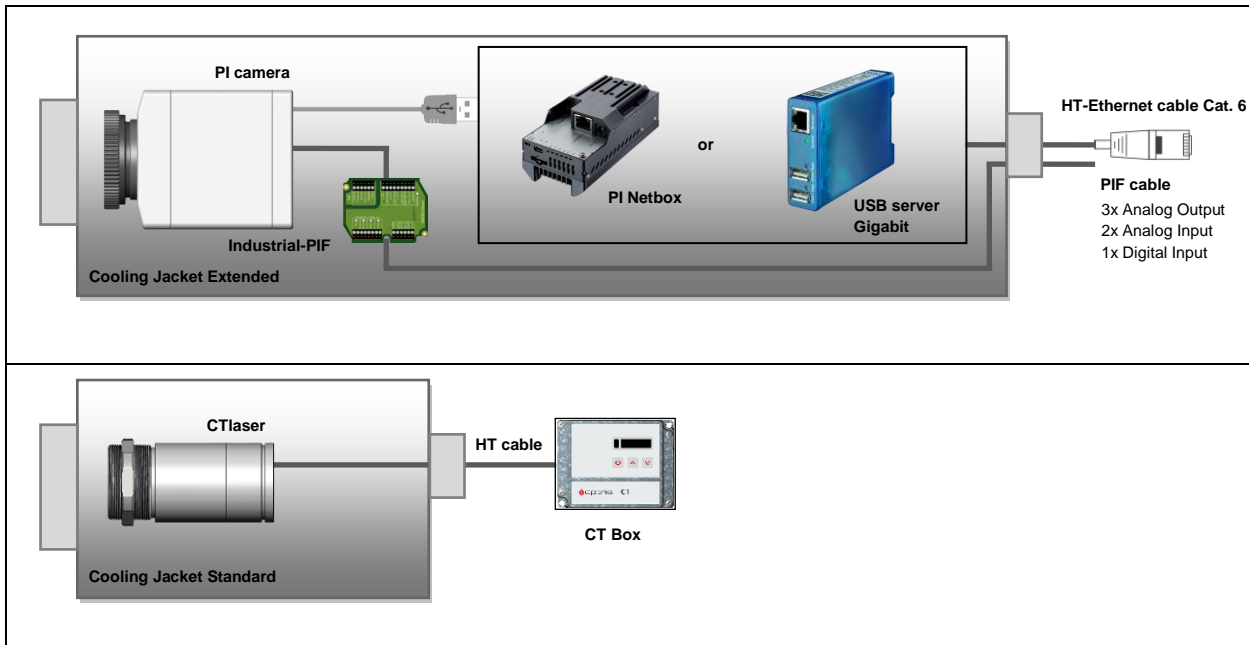

Figure 50: Chassis with PI camera, industrial PIF and USB server Gigabit

Follow as step 5, **page 51**.

4 Example of installation





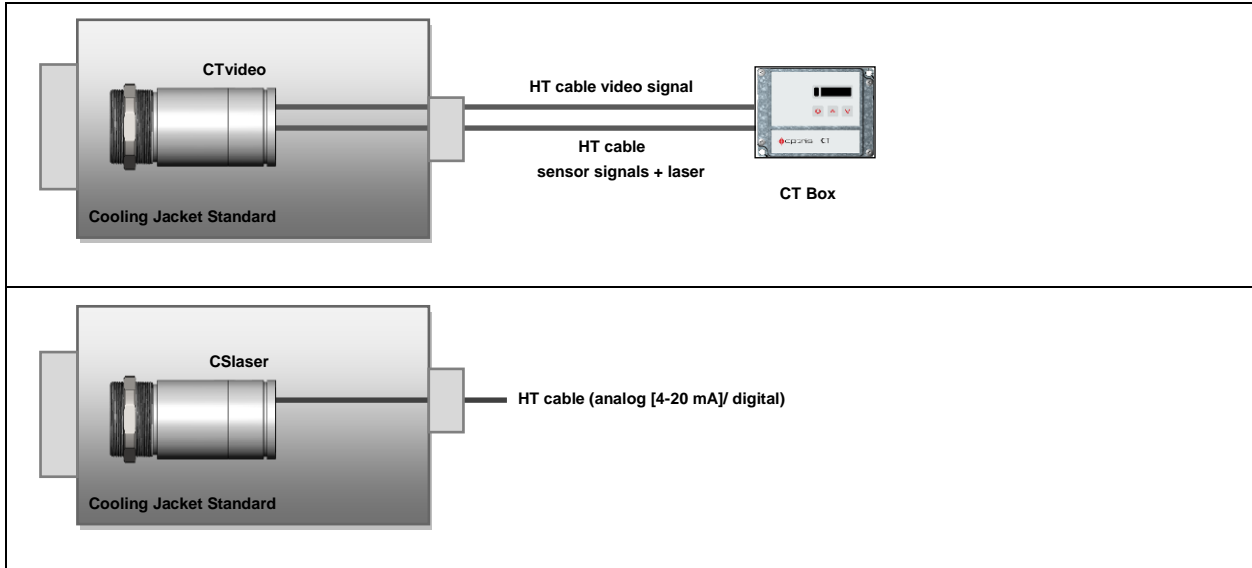

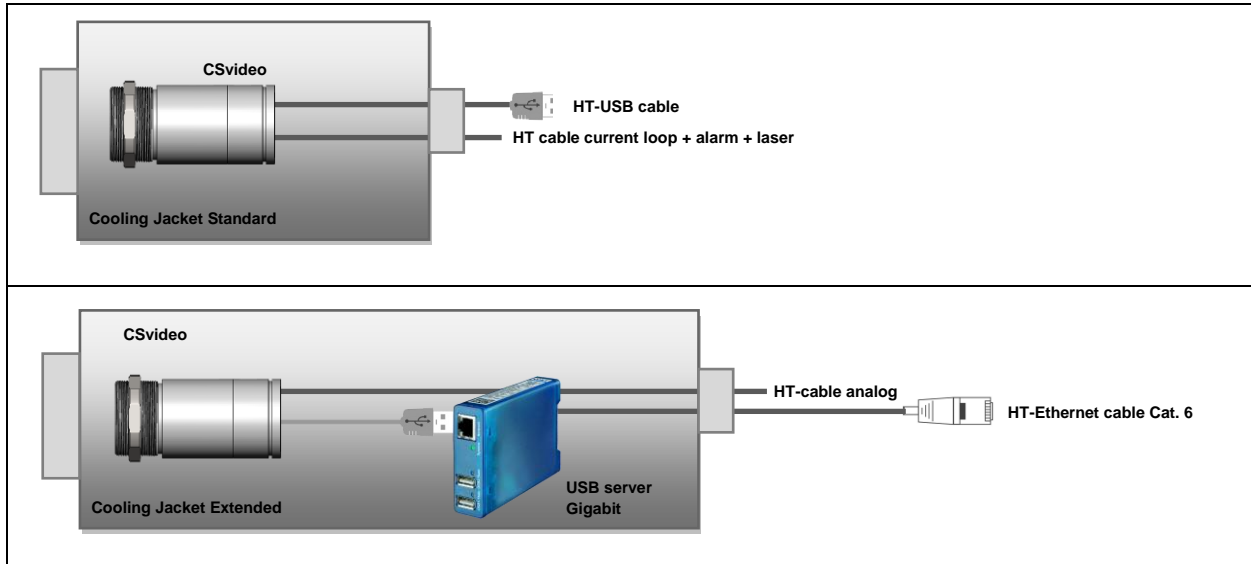

*All high temperature cables are available for temperatures up to 180 °C/ 250 °C:

- IR video thermometer and IR thermometer: 3 m, 8 m, 15 m
- HT-Ethernet cable Cat.6: 10 m und 20 m
- HT-USB cable: 5 m, 10 m



Figure 51: CoolingJacket (Standard) with CSvideo

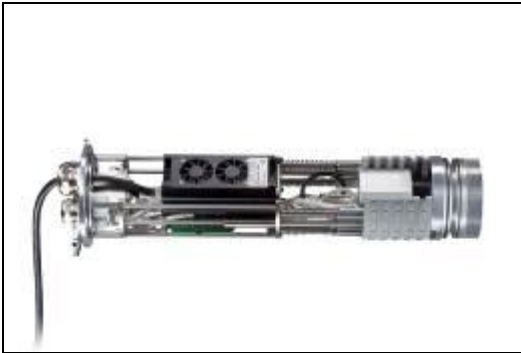

Figure 52: Cooling Jacket Advanced (Extended) with PI Netbox and industrial PIF



Figure 53: Cooling Jacket Advanced (Extended-Version) with USB Server and industrial PIF

optris CJA-MA-E2018-07-A