



Bezeichnung	G303M000
Modell	3" HMI Bediengerät
Schnittstellen	2x RS232, 1x RS485/422, 1x 10/100 Base-T-Ethernet, USB-Client: 1x USB 1.0 (Typ B)
Speicher	4 MB Flash, CompactFlash-Steckplatz für erhöhte Speicherkapazität
Versorgungsspannung	24 VDC
Software	Crimson® 3.1 inklusive
Optionen	-
Erweiterung	CF Kartensteckplatz
Funktionen	<ul style="list-style-type: none"> - Multiprotokollkonverter, - Webserver für Zugang zu kundenspezifischen Webseiten, virtuelles HMI, Daten und Ereignis-Logger, - FTP-Server und Synchronisation für Dateitransfer, - Alarmierung über SMS und Email
Anzahl simultane Ethernet-Protokolle	13
Gehäusematerial	Metall
Diagonale	3"
Abmessungen	189,2 x 148,6 x 52 mm
Auflösung	128 x 64



Anzahl Farben	monochrom
Helligkeit cd/m²	-
Hintergrundbeleuchtung	LCD mit gelber Hintergrundbeleuchtung
Programmierbare Funktionstasten	32
Touchtechnologie	-
Video-Normen	-
Schutzart	IP66 frontseitig
Gewicht	ca. 890 g
Betriebstemperatur	0°C ... 50°C
Montage	Fronteinbau, Wandmontage
Zertifizierung	Emission: IEC/EN 6100-6-4 für Industriestandorte, CISPR 11 Class A, RoHS-konform, Sicherheit: IEC/EN 61010-1, Störfestigkeit: IEC/EN 61000-6-2 für Industriestandorte, UL Gefahren Klasse 1, Div. 2 Gruppen A, B, C und D, UL-zertifiziert
Anwendung	Indoor
Artikelnummer	G303M000
Hersteller	Red Lion Controls



Tel +1 (717) 767-6511
Fax +1 (717) 764-0839
www.redlion.net

Bulletin No. G303-N
Drawing No. LP0561
Released 11/13

MODEL G303 - GRAPHIC LCD OPERATOR INTERFACE TERMINALS



FOR USE IN HAZARDOUS LOCATIONS:
Class I, Division 2, Groups A, B, C, and D
Class II, Division 2, Groups F and G
Class III, Division 2

- CONFIGURED USING CRIMSON 2.0 SOFTWARE
- UP TO 5 RS-232/422/485 COMMUNICATIONS PORTS (2 RS-232 AND 1 RS-422/485 ON BOARD, 1 RS-232 AND 1 RS422/485 ON OPTIONAL COMMUNICATIONS CARD)
- 10 BASE T/100 BASE-TX ETHERNET PORT TO NETWORK UNITS AND HOST WEB PAGES
- USB PORT TO DOWNLOAD THE UNIT'S CONFIGURATION FROM A PC OR FOR DATA TRANSFERS TO A PC
- UNIT'S CONFIGURATION IS STORED IN NON-VOLATILE MEMORY (4 MBYTE FLASH)
- COMPACTFLASH® SOCKET TO INCREASE MEMORY CAPACITY
- 3.2-INCH 128X64 PIXEL LCD WITH YELLOW LED BACKLIGHT, ABLE TO SUPPORT TEXT AND SIMPLE GRAPHICS
- OUTDOOR UNIT WITH UV RATED OVERLAY AVAILABLE
- 32 BUTTON KEYPAD WITH USER IDENTIFIABLE KEYS, NAVIGATIONAL KEYS, NUMERIC KEYS, KEYS FOR ON-SCREEN MENUS, AND OTHER VARIOUS KEYS.
- THREE FRONT PANEL LEDS
- POWER UNIT FROM 24 VDC ±20% SUPPLY



GENERAL DESCRIPTION

The G303 Operator Interface Terminal combines unique capabilities normally expected from high-end units with a very affordable price. It is built around a high performance core with integrated functionality. This core allows the G303 to perform many of the normal features of the Paradigm range of Operator Interfaces while improving and adding new features.

The G303 is able to communicate with many different types of hardware using high-speed RS232/422/485 communications ports and Ethernet 10 Base T/100 Base-TX communications. In addition, the G303 features USB for fast downloads of configuration files and access to trending and data logging. A CompactFlash socket is provided so that Flash cards can be used to collect your trending and data logging information as well as to store larger configuration files.

In addition to accessing and controlling of external resources, the G303 allows a user to easily view and enter information. The unit uses a Liquid Crystal Display (LCD) module, which is easily readable in both indoor and outdoor applications. Users can enter data through the front panel 32-button keypad that has user identifiable keys.

SAFETY SUMMARY

All safety related regulations, local codes and instructions that appear in the manual or on equipment must be observed to ensure personal safety and to prevent damage to either the instrument or equipment connected to it. If equipment is used in a manner not specified by the manufacturer, the protection provided by the equipment may be impaired.

Do not use the controller to directly command motors, valves, or other actuators not equipped with safeguards. To do so can be potentially harmful to persons or equipment in the event of a fault to the controller.



WARNING - EXPLOSION HAZARD - SUBSTITUTION OF COMPONENTS MAY IMPAIR SUITABILITY FOR CLASS I, DIVISION 2/CLASS II, DIVISION 2/CLASS III, DIVISION 2

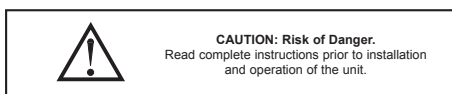

CompactFlash is a registered trademark of CompactFlash Association.

CONTENTS OF PACKAGE

- G303 Operator Interface.
- Panel gasket.
- Two user legendar key sheets.
- Template for panel cutout.
- Hardware packet for mounting unit into panel.
- Terminal Block for connecting power.

ORDERING INFORMATION

MODEL NO.	DESCRIPTION	PART NUMBER
G303	Operator Interface for indoor applications only, textured finish with embossed keys	G303M000
	Operator Interface for indoor or outdoor applications, glossy finish with UV rated overlay (keys are not embossed)	G303S000
G3CF	CompactFlash Card ⁶	G3CFxxxx
G3RS	RS232/485 Optional Communication Card	G3RS0000
G3CN	CANopen Optional Communication Card	G3CN0000
G3DN	DeviceNet Option Card With Isolated High Speed Communications Ports	G3DN0000
G3GSM	GSM/GPRS Modem Option Card ³	G3GSM000
G3PBDP	Profibus DP Optional Communication Card	G3PBDP00
SFCRM2	Crimson 2.0 ²	SFCRM200
CBL	RS-232 Programming Cable	CBLPROG0
	USB Cable	CBLUSB00
	Communications Cables ¹	CBLxxxxx
DR	DIN Rail Mountable Adapter Products ⁴	DRxxxxxx
	Replacement Battery ⁵	BNL20000
	Key Strip Paper	LBAFLM02
G3FILM	Protective Films	G3FILM03

¹ Contact your Red Lion distributor or visit our website for complete selection.
² Use this part number to purchase Crimson on CD with a printed manual, USB cable, and RS-232 cable. Otherwise, download from www.redlion.net.
³ Antenna (G3QANT00) is NOT included with the card. Must be purchased separately if needed.
⁴ Red Lion offers RJ modular jack adapters. Refer to the DR literature for complete details.
⁵ Battery type is lithium coin type CR2025.
⁶ Industrial grade two million write cycles. SMART Modular Technologies model SG9CF (UL Listed Directory Category NWGQ)

SPECIFICATIONS

1. POWER REQUIREMENTS:

+24 VDC ±20% @ 9.5 W maximum.

Must use a Class 2 circuit according to National Electrical Code (NEC), NFPA-70 or Canadian Electrical Code (CEC), Part I, C22.1 or a Limited Power Supply (LPS) according to IEC 60950-1 or Limited-energy circuit according to IEC 61010-1.

Power connection via removable three position terminal block.

Notes:

1. The front panel PWR LED indicates power.

2. The G303's circuit common is not connected to the enclosure of the unit. See "Connecting to Earth Ground" in the section "Installing and Powering the G303".

2. **BATTERY:** Lithium coin cell. Typical lifetime of 10 years.

3. **DISPLAY:** 3.2" 128 x 64 pixel FSTN LCD with yellow LED backlight for characters and simple graphics applications.

4. **32-KEY KEYPAD:** 8 user legendable keys, 5 navigational keys, 10+2 numeric keys, 4 dedicated keys, and 3 soft keys for on-screen menus.

5. **MEMORY:**

On Board User Memory: 4 Mbyte of onboard non-volatile Flash memory.

Memory Card: CompactFlash Type II slot for Type I and Type II CompactFlash cards.

6. **COMMUNICATIONS:**

USB Port: Adheres to USB specification 1.1. Device only using Type B connection.



WARNING - DO NOT CONNECT OR DISCONNECT CABLES WHILE POWER IS APPLIED UNLESS AREA IS KNOWN TO BE NON-HAZARDOUS. USB PORT IS FOR SYSTEM SET-UP AND DIAGNOSTICS AND IS NOT INTENDED FOR PERMANENT CONNECTION.

Serial Ports: Format and Baud Rates for each port are individually software programmable up to 115,200 baud.

PGM Port: RS232 port via RJ12.

COMMS Ports: RS422/485 port via RJ45, and RS232 port via RJ12. These two ports share the same hardware; the G303 multiplexes the ports to communicate via two protocols. These ports may be used to configure different master protocols, but only one port may be used if configuring a slave protocol or AB DH485.

DH485 TXEN: Transmit enable; open collector, $V_{OH} = 15$ VDC, $V_{OL} = 0.5$ V @ 25 mA max.

Note: For additional information on the communications or signal common and connections to earth ground please see "Connecting to Earth Ground" in the section "Installing and Powering the G303".

Ethernet Port: 10 BASE-T / 100 BASE-TX

RJ45 jack is wired as a NIC (Network Interface Card).

7. ENVIRONMENTAL CONDITIONS:

Operating Temperature Range: 0 to 50°C

Storage Temperature Range: -30 to 70°C

Operating and Storage Humidity: 80% maximum relative humidity (non-condensing) from 0 to 50°C.

Vibration to IEC 68-2-6: Operational 5 to 500 Hz, 3 g.

Shock to IEC 68-2-27: Operational 40 g

Altitude: Up to 2000 meters.

8. CERTIFICATIONS AND COMPLIANCES:

SAFETY

CE Approved

EN 61326-1 Immunity to Industrial Locations

Emission CISPR 11 Class B

IEC/EN 61010-1

RoHS Compliant

UL Listed: File #E179259

UL Hazardous: File #E211967

Type 4X Enclosure rating (Face only)

IP66 Enclosure rating (Face only)

IP20 Enclosure rating (Rear of unit)

9. **CONNECTIONS:** Compression cage-clamp terminal block.

Wire Gage: 12-30 AWG copper wire

Torque: 5-7 inch-pounds (56-79 N-cm)

10. **CONSTRUCTION:** Steel rear metal enclosure with NEMA 4X/IP66 aluminum front plate when correctly fitted with the gasket provided. Installation Category I, Pollution Degree 2.

11. **MOUNTING REQUIREMENTS:** Maximum panel thickness is 0.25" (6.3 mm). For NEMA 4X/IP66 sealing, a steel panel with a minimum thickness of 0.125" (3.17 mm) is recommended.

Maximum Mounting Stud Torque: 17 inch-pounds (1.92 N-m)

12. **WEIGHT:** 1.96 lbs (0.89 Kg)

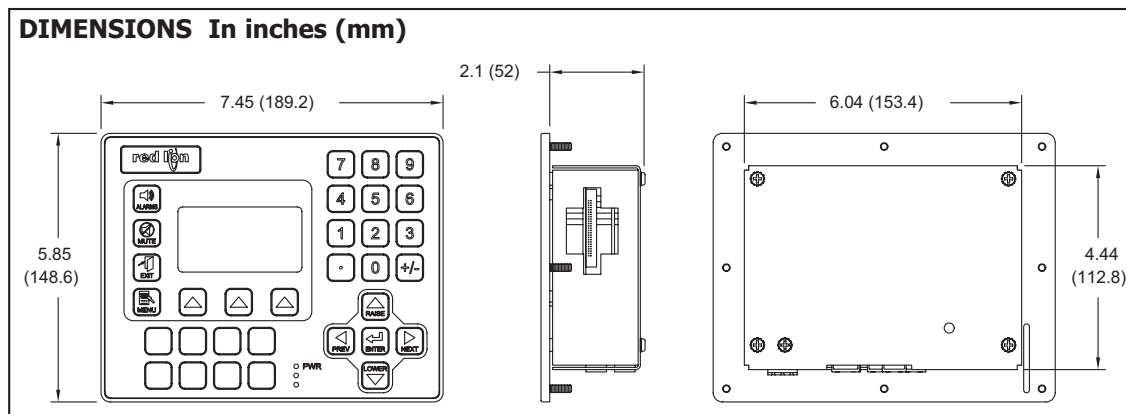

INSTALLING AND POWERING THE G303

USER IDENTIFIABLE KEYS

The G303 unit comes with a pre-printed key strip inserted. This key strip is labeled F1 through F8 and corresponds to Crimson software.

If desired, these keys may be custom labeled for specific functions. The default key strip may be removed and a custom key strip inserted. Each unit is delivered with two sheets of white "Cover 65" paper. This 8½ x11 paper may be used with most copiers, jet printers, or laser printers.

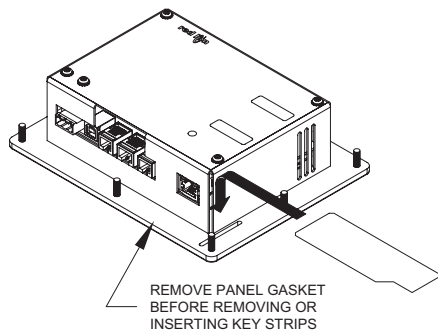

Custom key strips are made easily using the Adobe Acrobat file available from www.redlion.net or included with each Crimson CD. This program allows users to enter custom text and color schemes.

If more customization is needed, a graphics package can be used. The key strip dimensions are as follows.

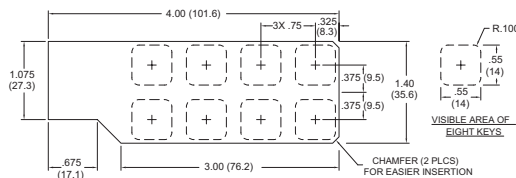

When inserting the key strip into the slot in the G303 panel, start one corner first then slowly insert the strip into place.

Note: Key strips need to be inserted into the unit before mounting into a panel.

MOUNTING INSTRUCTIONS

This operator interface is designed for through-panel mounting. A panel cut-out diagram and a template are provided. Care should be taken to remove any loose material from the mounting cut-out to prevent that material from falling into the operator interface during installation. A gasket is provided to enable sealing to NEMA 4X/IP66 specification. Install the eight kep nuts provided and tighten evenly for uniform gasket compression.

Note: tightening the kep nuts beyond a maximum of 17 inch-pounds (1.92 N-m) may cause damage to the front panel.

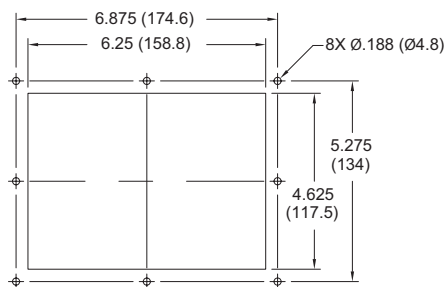

All tolerances ±0.010" (±0.25 mm).

ALL NONINCENDIVE CIRCUITS MUST BE WIRED USING DIVISION 2 WIRING METHODS AS SPECIFIED IN ARTICLE 501-4 (b), 502-4 (b), AND 503-3 (b) OF THE NATIONAL ELECTRICAL CODE, NFPA 70 FOR INSTALLATION WITHIN THE UNITED STATES, OR AS SPECIFIED IN SECTION 19-152 OF CANADIAN ELECTRICAL CODE FOR INSTALLATION IN CANADA.

CONNECTING TO EARTH GROUND

Each G303 has a chassis ground terminal on the back of the unit. Your unit should be connected to earth ground (protective earth).

The chassis ground is not connected to signal common of the unit. Maintaining isolation between earth ground and signal common is not required to operate your unit. But, other equipment connected to this unit may require isolation between signal common and earth ground. *To maintain isolation between signal common and earth ground care must be taken when connections are made to the unit.* For example, a power supply with isolation between its signal common and earth ground must be used. Also, plugging in a USB cable may connect signal common and earth ground.¹

1. USB's shield may be connected to earth ground at the host. USB's shield in turn may also be connected to signal common.

POWER SUPPLY REQUIREMENTS

The G303 requires a 24 VDC power supply rated at 9.5 W. Your unit may draw considerably less than 9.5 W depending upon the options being used. As additional features are used your unit will draw increasing amounts of power. Items that could cause increases in current are additional communications, optional communications card, Compact Flash card, and other features programmed through Crimson.

In any case, it is very important that the power supply is mounted correctly if the unit is to operate reliably. Please take care to observe the following points:

- The power supply must be mounted close to the unit, with usually not more than 6 feet (1.8 m) of cable between the supply and the operator interface. Ideally, the shortest length possible should be used.
- The wire used to connect the operator interface's power supply should be at least 22-gage wire. If a longer cable run is used, a heavier gage wire should be used. The routing of the cable should be kept away from large contactors, inverters, and other devices which may generate significant electrical noise.
- A power supply with a Class 2 or SELV rating is to be used. A Class 2 or SELV power supply provides isolation to accessible circuits from hazardous voltage levels generated by a mains power supply due to single faults. SELV is an acronym for "safety extra-low voltage." Safety extra-low voltage circuits shall exhibit voltages safe to touch both under normal operating conditions and after a single fault, such as a breakdown of a layer of basic insulation or after the failure of a single component has occurred.

COMMUNICATING WITH THE G303

CONFIGURING A G303

The G303 is configured using Crimson 2.0 software. Crimson is available as a free download from Red Lion's website, or it can be ordered on CD. Updates to Crimson for new features and drivers are posted on the website as they become available. By configuring the G303 using the latest version of Crimson 2, you are assured that your unit has the most up to date feature set. Crimson software can configure the G303 through the RS232 PGM port, USB port, or CompactFlash.

The USB port is connected using a standard USB cable with a Type B connector. The driver needed to use the USB port will be installed with Crimson.

The RS232 PGM port uses a programming cable made by Red Lion to connect to the DB9 COM port of your computer. If you choose to make your own cable, use the "G303 Port Pin Out Diagram" for wiring information.

The CompactFlash can be used to program a G3 by placing a configuration file and firmware on the CompactFlash card. The card is then inserted into the target G3 and powered. Refer to the Crimson literature for more information on the proper names and locations of the files.

CABLES AND DRIVERS

Red Lion has a wide range of cables and drivers for use with many different communication types. A list of these drivers and cables along with pin outs is available from Red Lion's website. New cables and drivers are added on a regular basis. If making your own cable, refer to the "G303 Port Pin Outs" for wiring information.

USB, DATA TRANSFERS FROM THE COMPACTFLASH CARD



WARNING - DO NOT CONNECT OR DISCONNECT CABLES WHILE POWER IS APPLIED UNLESS AREA IS KNOWN TO BE NON-HAZARDOUS. USB PORT IS FOR SYSTEM SET-UP AND DIAGNOSTICS AND IS NOT INTENDED FOR PERMANENT CONNECTION.

In order to transfer data from the CompactFlash card via the USB port, a driver must be installed on your computer. This driver is installed with Crimson and is located in the folder C:\Program Files\Red Lion Controls\Crimson 2.0\Device\ after Crimson is installed. This may have already been accomplished if your G303 was configured using the USB port.

Once the driver is installed, connect the G303 to your PC with a USB cable, and follow "Mounting the CompactFlash" instructions in the Crimson 2 user manual.

Note that using the USB port for frequent data transfers is not recommended. For frequent data transfers it is recommended that the Ethernet connection be used. Through the Ethernet connection a web page can be set up to view logged data. Refer to the Crimson 2.0 manual for details.

ETHERNET COMMUNICATIONS

Ethernet communications can be established at either 10 BASE-T or 100 BASE-TX. The G303 unit's RJ45 jack is wired as a NIC (Network Interface Card). For example, when wiring to a hub or switch use a straight-through cable, but when connecting to another NIC use a crossover cable.

The Ethernet connector contains two LEDs. A yellow LED in the upper right, and a bi-color green/amber LED in the upper left. The LEDs represent the following statuses:

LED COLOR	DESCRIPTION
YELLOW solid	Link established.
YELLOW flashing	Data being transferred.
GREEN	10 BASE-T Communications
AMBER	100 BASE-TX Communications

The Crimson 2 manual contains additional information on Ethernet communications.

RS232 PORTS

The G303 has two RS232 ports. There is the PGM port and the COMMS port. Although only one of these ports can be used for programming, both ports can be used for communications with a PLC.

The RS232 PGM port can be used for either master or slave protocols with any G303 configuration. The RS232 COMMS and RS422/485 COMMS ports are multiplexed because they share the same hardware. Both COMMS ports can be used with master protocols. However, when the RS232 COMMS port is used with a slave protocol, the RS422/485 COMMS port is not available.

Examples of RS232 communications could involve another Red Lion product or a PC. By using a cable with RJ12 ends on it, and a twist in the cable, RS232 communications with another G3 product or the Modular Controller can be established. Red Lion part numbers for cables with a twist in them are CBLPROG0¹, CBLRLC01², or CBLRC02³.

G3 RS232 to a PC

Connections			
G3: RJ12	Name	PC: DB9	Name
4	COMM	1	DCD
5	Tx	2	Rx
2	Rx	3	Tx
	N/C	4	DTR
3	COMM	5	GND
	N/C	6	DSR
1	CTS	7	RTS
6	RTS	8	CTS
	N/C	9	RI

CONNECTING A G303 OPERATOR INTERFACE TO AN ICM5

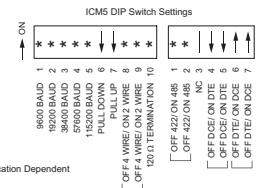
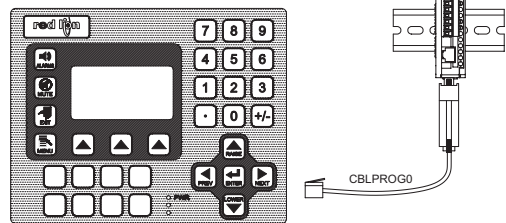

¹ CBLPROG0 can also be used to communicate with either a PC or an ICM5.
² DB9 adapter not included, 1 foot long.
³ DB9 adapter not included, 10 feet long.

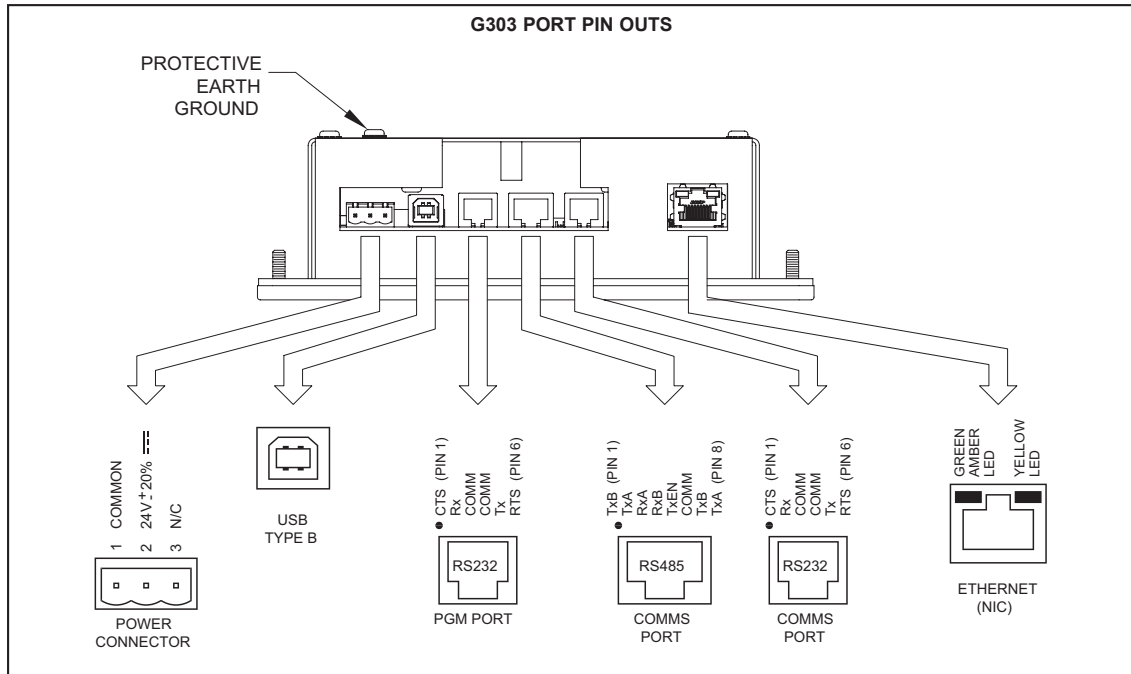

RS422/485 COMMS PORT

The G303 has one RS422/485 port. This port can be configured to act as either RS422 or RS485.

The RS422/485 COMMS and RS232 COMMS ports are multiplexed because they share the same hardware. Both COMMS ports can be used with master protocols. However, when the RS422/485 COMMS port is used with a slave protocol, the RS232 COMMS port is not available.

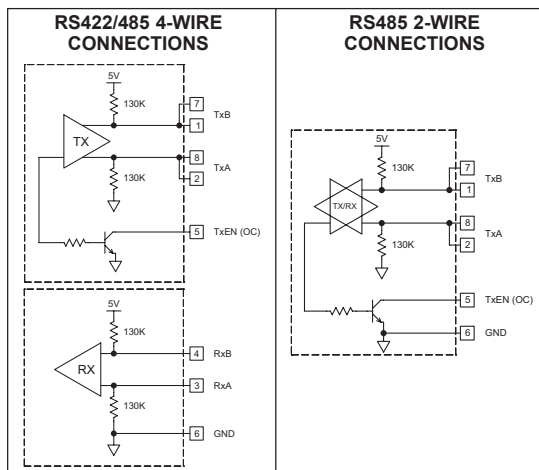

Note: All Red Lion devices connect A to A and B to B, except for Paradigm devices. Refer to www.redlion.net for additional information.

Examples of RS485 2-Wire Connections

G3 to Red Lion RJ11 (CBLRLC00) DLC, IAMS, ITMS, PAXCDC4C

Connections			
G3: RJ45	Name	RLC: RJ11	Name
5	TxEN	2	TxEN
6	COMM	3	COMM
1	TxB	5	B-
2	TxA	4	A+

G3 to Modular Controller (CBLRLC05)

Connections			
G3	Name	Modular Controller	Name
1,4	TxB	1,4	TxB
4,1	RxB	4,1	RxB
2,3	TxA	2,3	TxA
3,2	RxA	3,2	RxA
5	TxEN	5	TxEN
6	COMM	6	COMM
7	TxB	7	TxB
8	TxA	8	TxA

DH485 COMMUNICATIONS

The G303's RS422/485 COMMS port can also be used for Allen Bradley DH485 communications. When this port is configured to communicate DH485, the RS232 COMMS port can not be used because the ports share the same hardware and the G303 multiplexes the ports to communicate via two protocols.

WARNING: DO NOT use a standard DH485 cable to connect this port to Allen Bradley equipment. A cable and wiring diagram are available from Red Lion.

G3 to AB SLC 500 (CBLAB003)

Connections			
RJ45: RLC	Name	RJ45: A-B	Name
1	TxB	1	A
2	TxA	2	B
3, 8	RxA	-	24V
4, 7	RxB	-	COMM
5	TxEN	5	TxEN
6	COMM	4	SHIELD
4, 7	TxB	-	COMM
3, 8	TxA	-	24V

SOFTWARE/UNIT OPERATION

FRONT PANEL LEDS

There are three front panel LEDs. Shown below is the default status of the LEDs.

LED	INDICATION
RED (TOP, LABELED "PWR")	
FLASHING	Unit is in the boot loader, no valid configuration is loaded. ¹
STEADY	Unit is powered and running an application.
YELLOW (MIDDLE)	
OFF	No CompactFlash card is present.
STEADY	Valid CompactFlash card present.
FLASHING RAPIDLY	CompactFlash card being checked.
FLICKERING	Unit is writing to the CompactFlash, either because it is storing data, or because the PC connected via the USB port has locked the drive. ²
FLASHING SLOWLY	Incorrectly formatted CompactFlash card present.
GREEN (BOTTOM)	
FLASHING	A tag is in an alarm state.
STEADY	Valid configuration is loaded and there are no alarms present.

1. The operator interface is shipped without a configuration. After downloading a configuration, if the light remains in the flashing state continuously, try cycling power. If the LED still continues to flash, try downloading a configuration again.
2. Do not turn off power to the unit while this light is flickering. The unit writes data in two minute intervals. Later Microsoft operating systems will not lock the drive unless they need to write data; Windows 98 may lock the drive any time it is mounted, thereby interfering with logging. Refer to "Mounting the CompactFlash" in the Crimson 2 User Manual.

CRIMSON SOFTWARE

Crimson software is available as a free download from Red Lion's website or it can be purchased on a CD, see "Ordering Information" for part number. The latest version of the software is always available from the website, and updating your copy is free.

KEYPAD

The G303 keypad consists of five unique key types. There are eight legendable keys (refer to "User Legendable Keys" for more information). A five key navigational keypad area. A twelve key numeric keypad with ± and decimal point. Three soft keys for on-screen menu selections. And, four keys labeled ALARMS, MUTE, EXIT, and MENU.

TROUBLESHOOTING YOUR G303

If for any reason you have trouble operating, connecting, or simply have questions concerning your new G303, contact Red Lion's technical support. For contact information, refer to the back page of this bulletin for phone and fax numbers.

EMAIL: techsupport@redlion.net

Web Site: <http://www.redlion.net>

BATTERY & TIME KEEPING



WARNING - EXPLOSION HAZARD - THE AREA MUST BE KNOWN TO BE NON-HAZARDOUS BEFORE SERVICING/ REPLACING THE UNIT AND BEFORE INSTALLING OR REMOVING I/O WIRING AND BATTERY.



WARNING - EXPLOSION HAZARD - DO NOT DISCONNECT EQUIPMENT UNLESS POWER HAS BEEN DISCONNECTED AND THE AREA IS KNOWN TO BE NON-HAZARDOUS.

A battery is used to keep time when the unit is without power. Typical accuracy of the G303 time keeping is less than one minute per month drift. The battery of a G303 unit has no affect on the unit's memory as all configurations and data are stored in non-volatile memory.



CAUTION: The circuit board contains static sensitive components. Before handling the operator interface without the rear cover attached, discharge static charges from your body by touching a grounded bare metal object. Ideally, handle the operator interface at a static controlled clean workstation. Also, do not touch the surface areas of the circuit board. Dirt, oil, or other contaminants may adversely affect circuit operation.

To change the battery of a G303, remove power, cabling, and then the rear cover of the unit. To remove the cover, remove the four screws designated by the arrows on the rear of the unit. Then, by lifting the top side, hinge the cover, thus providing clearance for the connectors on the bottom side of the PCB as shown in the illustration below. Install in the reverse manner.

Remove the old battery* from the holder and replace with the new battery. Replace the rear cover, cables, and re-apply power. Using Crimson or the unit's keypad, enter the correct time and date.

** Please note that the old battery must be disposed of in a manner that complies with your local waste regulations. Also, the battery must not be disposed of in fire, or in a manner whereby it may be damaged and its contents come into contact with human skin.*

The battery used by the G303 is a lithium type CR2025.

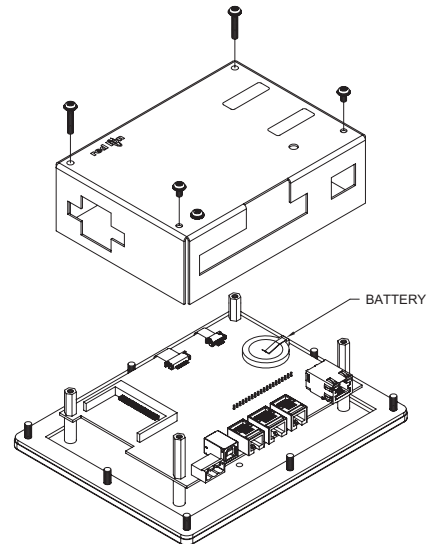
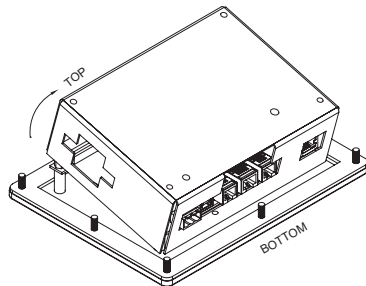

OPTIONAL FEATURES AND ACCESSORIES

INDOOR VERSUS OUTDOOR

Red Lion offers two versions of its G303 unit. The G303M000 uses an overlay with a textured finish and keys that are embossed. This overlay is not rated for outdoor use. The G303S000 uses an overlay with a glossy finish that uses a UV rated material for outdoor use. The keys on this overlay are not embossed.

OPTIONAL COMMUNICATION CARD

Red Lion offers optional communication cards for fieldbus communications. These communication cards will allow your G303 to communicate with many of the popular fieldbus protocols.

Red Lion is also offering a communications card for additional RS232 and RS422/485 communications. Visit Red Lion's website for information and availability of these cards.

CUSTOM LOGO

Each G3 operator interface has an embossed area containing the Red Lion logo. Red Lion can provide custom logos to apply to this area. Contact your distributor for additional information and pricing.

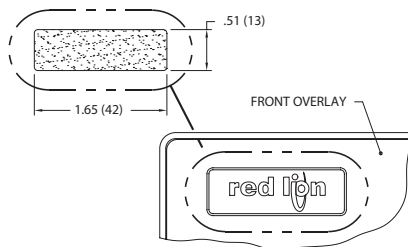

COMPACTFLASH SOCKET

CompactFlash socket is a Type II socket that can accept either Type I or II cards. Use cards with a minimum of 4 Mbytes and formatted to a maximum of 2 Gbytes (see Note box below) with the G303's CompactFlash socket. Cards are available at most computer and office supply retailers.

CompactFlash can be used for configuration transfers, larger configurations, data logging, and trending.

Note: Do not remove or insert the CompactFlash card while power is applied. Refer to front panel LEDs.

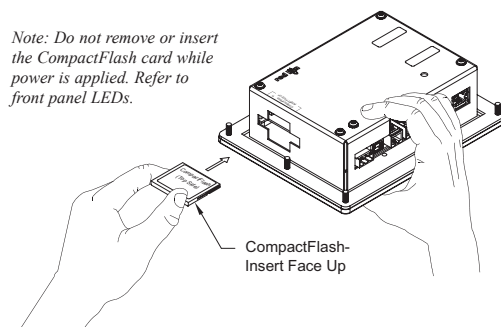

Information stored on a CompactFlash card by a G303 can be read by a card reader attached to a PC. This information is stored in IBM (Windows®) PC compatible FAT16 file format.

NOTE

For reliable operation of this and other Red Lion products, one of the following brands of CompactFlash card must be used...

SimpleTech SMART® Modular
SanDisk® Silicon Systems

Not all of the above manufacturers offer CompactFlash cards recognized to UL standards, which may be required for your application.

Although RLC products limit use of CompactFlash card memory to 2 GB, cards with a larger capacity can be used. They MUST be formatted to 2 GB and use the FAT 16 file system. It is recommended to format the CF card using the format utility from within Crimson.

LIMITED WARRANTY

The Company warrants the products it manufactures against defects in materials and workmanship for a period limited to two years from the date of shipment, provided the products have been stored, handled, installed, and used under proper conditions. The Company's liability under this limited warranty shall extend only to the repair or replacement of a defective product, at The Company's option. The Company disclaims all liability for any affirmation, promise or representation with respect to the products.

The customer agrees to hold Red Lion Controls harmless from, defend, and indemnify RLC against damages, claims, and expenses arising out of subsequent sales of RLC products or products containing components manufactured by RLC and based upon personal injuries, deaths, property damage, lost profits, and other matters which Buyer, its employees, or sub-contractors are or may be to any extent liable, including without limitation penalties imposed by the Consumer Product Safety Act (P.L. 92-573) and liability imposed upon any person pursuant to the Magnuson-Moss Warranty Act (P.L. 93-637), as now in effect or as amended hereafter.

No warranties expressed or implied are created with respect to The Company's products except those expressly contained herein. The Customer acknowledges the disclaimers and limitations contained herein and relies on no other warranties or affirmations.

Red Lion Controls
Headquarters
20 Willow Springs Circle
York PA 17406
Tel +1 (717) 767-6511
Fax +1 (717) 764-0839

Red Lion Controls
Europe
Softwareweg 9
NL - 3821 BN Amersfoort
Tel +31 (0) 334 723 225
Fax +31 (0) 334 893 793

Red Lion Controls
India
201-B, 2nd Floor, Park Centra
Opp 32 Mile Stone, Sector-30
Gurgaon-122002 Haryana, India
Tel +91 984 487 0503

Red Lion Controls
China
Unit 302, XinAn Plaza
Building 13, No.99 Tianzhou Road
ShangHai, P.R. China 200223
Tel +86 21 6113 3688
Fax +86 21 6113 3683