

Datenblatt

Graphite® Standard Expansion Rack

GEXRACK2



Bezeichnung	GEXRACK2
Modell	Graphite® Standard Expansion Rack für weitere Plugin-Module
Produktreihe	Graphite Edge Controller, Graphite HMI
Zubehör	Erweiterung
Beschreibung	3 Modulsteckplätze pro Rack zur Erweiterung der Funktionen - 1 Wide und bis zu 3 Standard-Racks können zusammen installiert werden

Graphite® Expansion Racks

Red Lion Automation Series



▶▶▶ Industrial Modularity for Graphite Platform

Easily panel mount the I/O and communication capabilities of Red Lion's Graphite® platform using rugged USB modular expansion racks.

Rugged Graphite expansion racks allow for easy back-of-cabinet mounting and support for additional plug-in modules without extensive wiring. These expansion racks work with the Graphite platform to provide a scalable solution that enables organizations to connect, monitor and control more industrial processes.



Standard Rack



Wide Rack

INDUSTRY APPLICATIONS

- > Factory Automation
- > Oil & Gas
- > Power & Utilities
- > Plastic Extrusion
- > Data Acquisition
- > Water/Wastewater
- > Industrial Internet of Things (IIoT)

PRODUCT HIGHLIGHTS

- > USB Cable Connects Expansion Rack to Graphite Platform
- > Support for Additional Plug-In Modules
- > Wide -40° to 75°C Operating Temperature*
- > Rugged Industrial Design for Harsh Environments

FEATURES & BENEFITS

- > Remote Module Mounting
 - Easy back-of-cabinet installation
 - Minimizes I/O cabling to cabinet door
- > Extend Graphite Platform Capabilities
 - Support for additional plug-in modules
- > Rugged Environmental Specifications
 - Wide -40° to 75°C operating temperature*
 - High shock and vibration tolerance
 - CE, UL/cUL and UL/cUL Hazardous approvals
- > Multiple Models Available
 - Wide expansion rack includes USB host and power for connected modules
 - Filtered power supply for module and Graphite platform
 - 3 module slots per rack
 - Standard expansion rack mates to wide rack
 - 3 module slots per rack
 - Mounting options include DIN rail or direct mount

industrial
automation



▶▶▶ **Graphite Expansion Rack Specifications**

POWER INPUT

Input Voltage: 9-32 VDC
 Must use a Class 2 circuit according to National Electrical Code (NEC), NFPA-70 or Canadian Electrical Code (CEC), Part I, C22.1 or a Limited Power Supply (LPS) according to IEC 60950-1 or limited-energy circuit according to IEC 61010-1.
 Power Requirements (Expansion Rack): 13 W per rack; 52 W total
 Power Requirements (Graphite Host):

Model	Typical	Max	With Modules	Module Slots	Max Modules
G07C	9 W	16 W	37 W	5	17
G07S	10 W	17 W	38 W	5	17
G09	13 W	20 W	45 W	6	18
G10C/R	12 W	19 W	48 W	7	19
G10S	18 W	24 W	53 W	7	19
G12	16 W	23 W	56 W	8	20
G15	20 W	27 W	60 W	8	20

CONNECTORS

USB Host: One (1) USB Type A - complies with USB specification 2.0;
 Supports full-speed data transfers
 Power: High compression cage-clamp terminal block
 Wire Strip Length: 0.3" (7.5 mm)
 Wire Gauge Capacity: One 14 AWG (1.63 mm) solid, two 18 AWG (1.02 mm) or four 20 AWG (0.81 mm)

ENVIRONMENTAL

Operating Temperature: -40°C to 75°C*
 Storage Temperature: -40°C to 85°C
 Operating Humidity: 0% to 80% (non-condensing, from 0 to 50°C)
 Altitude: Up to 2000 meters
 Panel Mount Vibration: IEC 68-2-6; Operational 5-500 Hz, 4 g
 Panel Mount Shock: IEC 68-2-27; Operational 40 g (10 g, modules w/ relays)
 DIN Rail Mount Vibration: IEC 68-2-6; Operational 5-500 Hz, 2 g**
 DIN Rail Mount Shock: IEC 68-2-27; Operational 15 g (10 g, modules w/relays)**
 Requires DIN Rail type: DIN 1010, DIN 1065 or DIN 3065

CERTIFICATIONS AND COMPLIANCES

Product Safety:
 CE Approved
 EN 61326-1 Immunity to Industrial Locations Emission CISPR 11 Class A
 IEC/EN 61010-1
 cULus Listed: File #E302106
 cULus Hazardous: File #E317425
 Other:
 RoHS Compliant

MECHANICAL

Case body is all metal. Installation Category II, Pollution Degree 2 as defined in IEC 60664-1
 Wide Rack (Base):
 Height: 5.97" (15.1 cm)
 Width: 5.83" (14.7 cm)
 Depth: 4.4" (11.2 cm)
 Weight: 1.78 lbs (0.79 kg)
 Standard Rack (Expansion):
 Height: 5.97" (15.1 cm)
 Width: 3.96" (10.1 cm)
 Depth: 4.4" (11.2 cm)
 Weight: 1.33 lbs (0.59 kg)
 Mounting: Panel mount or DIN rail

Specifications are subject to change. Visit www.redlion.net for more information.

* Modules or host devices may restrict temperature; refer to module documentation.
 ** DIN latch CAM must be in latched position

DIMENSIONS

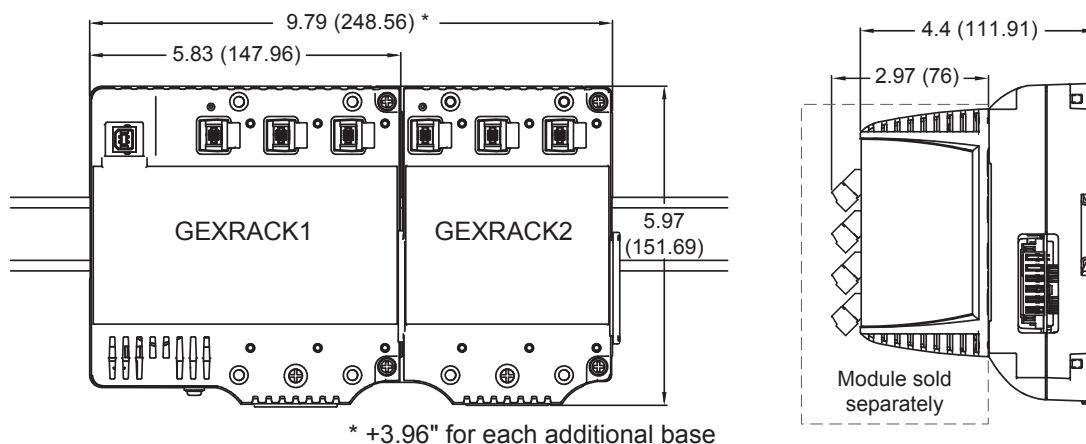

▶▶▶ Graphite Expansion Rack Specifications

ORDERING GUIDE

MODEL NUMBER	DESCRIPTION
GEXRACK1	Graphite Wide Expansion Rack for Modules
GEXRACK2	Graphite Standard Expansion Rack for Modules
CBLUSBM0	USB Tethering Cable, 0.5 M Metal Jacketed
CBLUSBM1	USB Tethering Cable, 1 M Metal Jacketed
CBLUSBM2	USB Tethering Cable, 2 M Metal Jacketed

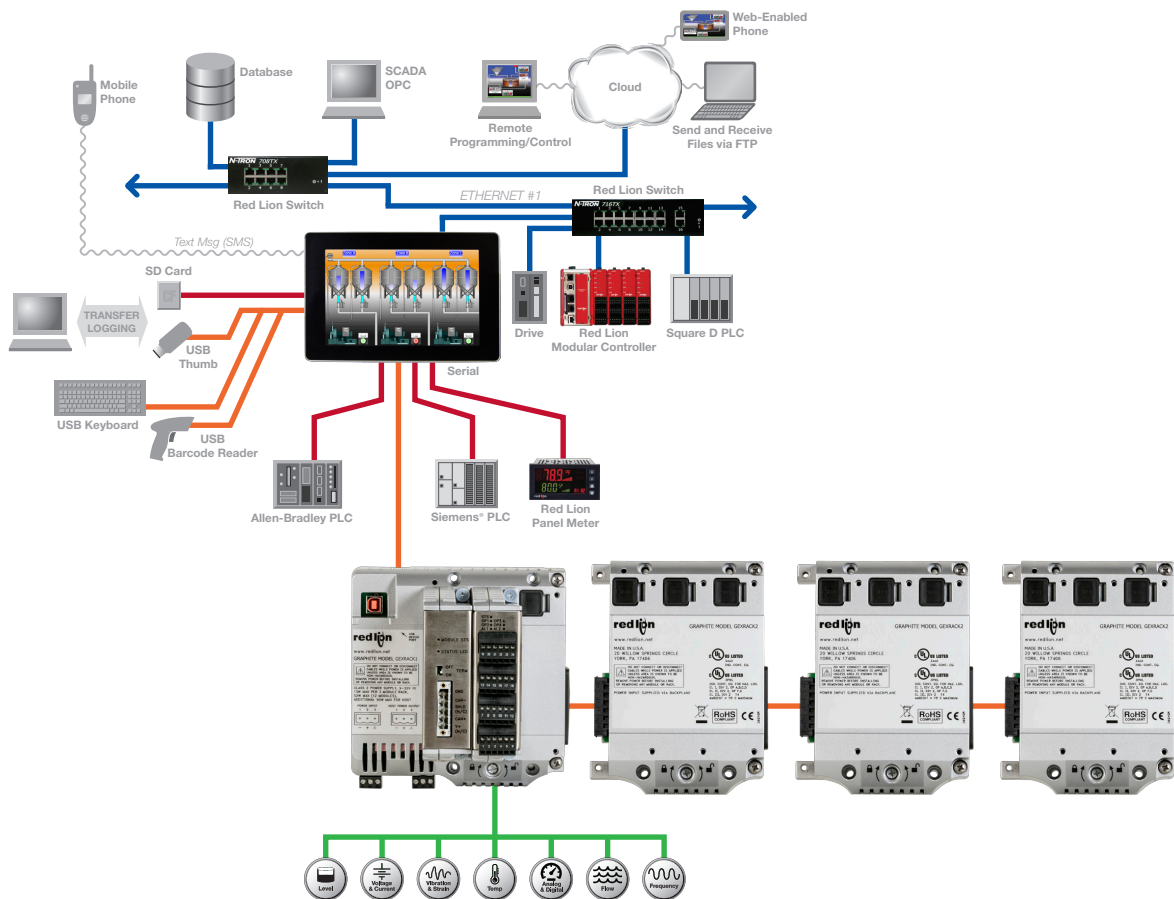

www.redlion.net

Connect. Monitor. Control.

Americas
 sales@redlion.net
Asia-Pacific
 asia@redlion.net
Europe
Middle East
Africa
 europe@redlion.net
 +1 (717) 767-6511

As the global experts in communication, monitoring and control for industrial automation and networking, Red Lion has been delivering innovative solutions for over forty years. Our automation, Ethernet and cellular M2M technology enables companies worldwide to gain real-time data visibility that drives productivity. Product brands include Red Lion, N-Tron and Sixnet. With headquarters in York, Pennsylvania, the company has offices across the Americas, Asia-Pacific and Europe. Red Lion is part of Spectris plc, the productivity-enhancing instrumentation and controls company. For more information, please visit www.redlion.net.

ADLD0463 100516 © 2016 Red Lion Controls, Inc. All rights reserved. Red Lion, the Red Lion logo, N-Tron and Sixnet are registered trademarks of Red Lion Controls, Inc. All other company and product names are trademarks of their respective owners.