

Datenblatt

50mm Edelstahltrackball als Einbaumodul

GS50



Bezeichnung	GS50
Ausführung	OEM-Einbaumodul
Cursorsteuerung	Edelstahltrackball
Technologie	mechanisch
Balldurchmesser	50,8 mm
Ballmaterial	Edelstahl
Gehäusematerial	Kunststoff
Schutzgrad	IP54 statisch
Betriebstemperatur	-10°C ... +60°C
Abmessungen	77,5 x 79,5 x 52 mm
Schnittstelle	PS2, USB, Matrix
Zusatzfunktion	ohne
Zertifizierung	CE
Artikelnummer	GS50-4002 (P50-50028C), GS50-4502, GS50-4602 (P50-56028C), TKH-TB50V
Einsatzbereich	Industrie, Gerätebau, Vandalismusschutz

50 MM STAINLESS STEEL TRACKBALL MODULE

IP54 sealed



The GS50 series are ruggedised professional trackballs. The ball and the trim are made of quality stainless steel giving the unit a stylish all metal look. The double-sided seal ring provides a sealing to IP54. Stainless steel shafts and bearings ensure a solid and precise pointer control.

GENERAL TECHNICAL SPECIFICATIONS

Sealing	: IP54
Casing material	: ABS/Polycarbonate
Ball & trim material	: Stainless steel
Ball diameter	: 50,8 mm
Weight	: 700 grams
Seal material	: PTFE composite
Shaft diameter	: 9,5 mm
Tracking force	: 60 grams nominal
Mounting angle	: Max. 60° to horizontal plane
Lifetime - Ball revolutions	: > 2 million
Supply voltage (quadrature)	: 5 Vdc +/- 5%
Supply current (quadrature)	: 6 mA typ
Storage temperature	: -25°C to +80°C
Operating temperature	: -10°C to +60°C
Relative humidity	: 95% non-condensing
Vibration	: 5G, 5-2KHz any plane

CONNECTIVITY

The GS50-4502 is PS/2 compatible. The GS50-4602 can be plugged into any USB port or hub. Both types are supplied with 1,6m long shielded straight cables and external switch cables.

The GS50-4002 has phase quadrature output: X1(Y1) leads X2(Y2) when motion of ball in positive X(Y) direction. No device driver is supplied with the unit. Please use standard available drivers in your operating system. It is supplied with a 10-way connection cable of 35 cm.

* Due to the increasing differences of the mouse port specifications of the various PC manufacturers, we do recommend that this unit should be tested on the final PC configuration and operating system prior to installing it in series.

ORDER INFO

OUTPUT	ORDER NUMBER	Consisting of :
Quadrature	GS50-4002	P50-50028C Trackball module only IC101035 : 35 cm interconnection cable to CON 1
PS/2	GS50-4502	P50-56028C : Trackball module only OC6010160 : 1,6 m shielded PS/2 cable with 6 pin mini DIN plug IC040035 : 35 cm switch cable (4 wires) to CON2
USB	GS50-4602	P50-56028C : Trackball module only OC5010160 : 1,6 m shielded cable with USB type A plug IC040035 : 35 cm switch cable (4 wires) to CON2

VER. 1.1

50 MM STAINLESS STEEL TRACKBALL MODULE

DIMENSIONAL DRAWING

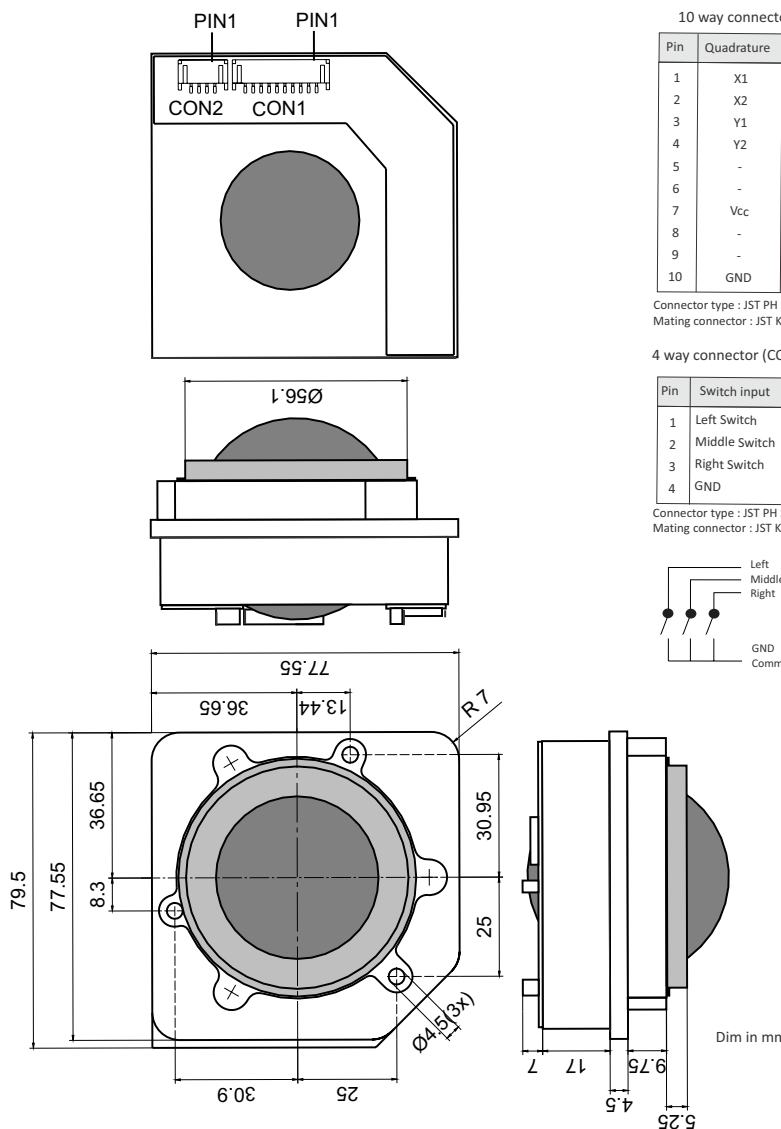

Dip switches : leave off, for factory use only.

10 way connector (CON1)

Pin	Quadrature	PS/2 or USB
1	X1	X1
2	X2	X2
3	Y1	Y1
4	Y2	Y2
5	-	-
6	-	-
7	Vcc	Vcc
8	-	Data/D-
9	-	CLK/D+
10	GND	GND

Connector type : JST PH Series 2,0mm pitch.
Mating connector : JST KR Series 2,0mm pitch.

4 way connector (CON2) for PS/2 & USB only

Pin	Switch input
1	Left Switch
2	Middle Switch
3	Right Switch
4	GND

Connector type : JST PH Series 2,0mm pitch.
Mating connector : JST KR Series 2,0mm pitch.

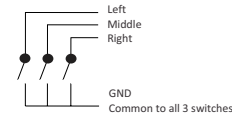

The company reserves the right to alter without prior knowledge the specification or design of any standard product or service.