

Datenblatt

N-TRON NT-5018-DM2 Managed 18-Port Gigabit Switch

NT-5018-DM2



Bezeichnung	NT-5018-DM2
Modell	N-TRON Managed Gigabit Switch
Typ	Managed Switch
Gesamtzahl Ports	18
10/100/1000 Kupfer	16
Übertragungsrate	10/100/1000 Mbit/s
Anzahl MAC Adressen	8k
Betriebstemperatur	-40°C ... +80°C
Lagertemperatur	-40°C ... +85°C
Versorgungsspannung	10-49 VDC
100/1000 SFP Slot	2
Gehäusematerial	Metall
Montage	DIN-Hutschiene, optional Wandmontage
Abmessungen	150,6 x 57,1 x 129,8 mm
Gewicht	620 g

Datenblatt

N-TRON NT-5018-DM2 Managed 18-Port Gigabit Switch

NT-5018-DM2



Besonderheiten

N-Ring™ Technologie mit ~30ms healing
Password encryption, IEEE 802.1X, RADIUS, MAC filtering, syslog
Advanced management and diagnostics features
MTBF: 1,2 Mio. h
Shock & Vibration (panel mounted):
IEC 68-2-27: 200 g @ 10 ms Triaxial; non-operational
IEC 68-2-6: 15 g @ 5-200 Hz Triaxial; operational

Zertifizierung

ABS Type Approval for Shipboard Applications, Designed to Comply with: IEEE 1613 (Electric Utility Substations), NEMA TS1/TS2 (Traffic Control), EMI/EMC: CFR 47, Part 15, Subpart B, Canada ICES-003, ANSI C63.4, EN 61000-6-2 and 4, IEC 61000-4-2, 3, 4, 5, 6 and 8, Product Safety: UL 61010 and C22.2 No. 61010 OrdLoc, UL 121201 and CSA C22.2 No. 213 Class I, Division 2 HazLoc, ATEX, IECEx and UKEx II 3 G Ex ec nC IIC T4 Gc, UL 20 ATEX 2645X, UL 22.0038X IECEx and UL22UKEX2346X, Rail: EN 50155, EN50121, EN61373, RoHS, Shock & Vibration (panel mounted) - IEC 68-2-27: 200 g @ 10 ms Triaxial; non-operational, IEC 68-2-6: 15 g @ 5-200 Hz Triaxial; operational

Datenblatt

N-TRON NT-5018-DM2 Managed 18-Port Gigabit Switch NT-5018-DM2



N-Tron® Series NT5018-DM2



Gigabit Managed Ethernet Switch

The NT5018-DM2 Gigabit Industrial Switch sets a new standard for performance, reliability, and ease of use. The switch features a modern, graphical user interface with a quick start wizard to guide users through switch configuration. A logical view of the switch shows active ports, temperature, alarm and LED status, along with port traffic and event gauges in a single easy to read dashboard.

Features include:



- Sixteen 10/100/1000 RJ45 ports
- Two dual mode 100/1000Base SFP expansion slots; supports 100Base or 1000Base SFP transceivers
- Redundant 10–49 VDC power inputs
- High shock and vibration tolerance
- N-Ring™ technology with ~30ms healing and RSTP/MSTP network redundancy
- Password encryption, IEEE 802.1X, RADIUS, MAC filtering, syslog
- Advanced management and diagnostics features



Ordering Guide

Main Unit

Part Number	Description
NT-5018-DM2-0000	18-Port Gigabit Managed Industrial Ethernet Switch (16 10/100/1000BaseT RJ45 Ports, 2 Dual Mode 100/1000Base SFP Expansion Slots)

Model number may be followed by -CC indicating conformal coating.

Accessories

Part Number	Description
NT-CPMA-03-00000	NT5000 Panel Mount Kit, Type A (Wide)
NTPS-24-1-3	DIN Rail Power Supply, 1.3 Amp @ 24 VDC
NTSFP-FX	100BaseFX Multimode Fiber SFP Transceiver (LC Style Connector, 2 km)
NTSFP-FXE-15	100BaseFX Singlemode Fiber SFP Transceiver (LC Style Connector, 15km)
NTSFP-FXE-40	100BaseFX Singlemode Fiber SFP Transceiver (LC Style Connector, 40 km)

www.redlion.net

NT5018-DM2 Specifications

Part Number	Description
NTSFP-FXE-80	100BaseFX Singlemode Fiber SFP Transceiver (LC Style Connector, 80 km)
NTSFP-SX	1000BaseSX Multimode Fiber SFP Transceiver (LC Style Connector, 550 m)
NTSFP-LX-10	1000BaseLX Singlemode Fiber SFP Transceiver (LC Style Connector, 10 km)
NTSFP-LX-40	1000BaseLX Singlemode Fiber SFP Transceiver (LC Style Connector, 40 km)
NTSFP-LX-80	1000BaseLX Singlemode Fiber SFP Transceiver (LC Style Connector, 80 km)
NTSFP-TX	1000BaseT Copper SFP Transceiver (RJ45 Connector)

Specifications

Hardware

Compact, space saving, hardened industrial design
Wide operating temperature
High shock and vibration tolerance
Shock: IEC 68-2-27: 200 g @ 10 ms Triaxial; non-operational; panel mounted
Vibration: IEC 68-2-6: 15 g @ 5-200 Hz Triaxial; operational; panel mounted
Reverse polarity protection
ESD and surge protection
Fast boot (traffic passes <20 seconds)
Configurable alarm contact
Configurable bi-color fault status LED
LED port status indicators
Jumbo frame support
Redundant power inputs (10-49 VDC)
Hardened industrial design
IEEE 802.3 compliance
Full wire speed communication
MDIX auto-sensing cable
Auto-sensing speed and flow control
Up to 36.0 Gb/s maximum throughput
Store-and-forward technology
Number of MAC addresses: Up to 8k
Latency (typical): < 1.8 µs
MTBF: 1.2M Hours

Management

Modern, intuitive Web Interface
Configuration wizard
Graphical dashboard and logical view of the switch
Command Line Interface
Port control
IGMP v1/v2/v3 auto-configuration
SNMP v1/v2/v3
NTP
802.1Q tag VLAN and port VLAN
IEEE 802.1p QoS and port QoS
Text-based configuration file
File transfer: HTTP/HTTPS, TFTP, SNMP
DHCP Server, Option 82 relay, Option 61, IP fallback

Security

SSH, SSL, HTTPS
MAC Filtering

IEEE 802.1X with RADIUS remote server authentication
Port/User lockout after failed authentication attempts
SNMPv3
Password encryption

Diagnostic

Port mirroring
Event log/Syslog
LLDP
Advanced cable diagnostics

Network Redundancy

RSTP/MSTP
Port trunking/LACP
N-Ring™ technology with ~30ms healing

MIBs

RFC 2674 VLAN MIB
RFC 2819 RMON (Group 1, 2, 3 & 9)
RFC 1213 MIB II
RFC 1215 TRAPS MIB
RFC 4188 Bridge MIB
RFC 4292 IP Forwarding Table MIB
RFC 4293 Management Information Base for the Internet Protocol (IP)
RFC 5519 Multicast Group Membership Discovery MIB
RFC 2863 Interface Group MIB using SMI v2
RFC 4133 Entity MIB version 3
RFC 3411 SNMP Management Frameworks
RFC 3414 User-based Security Model for SNMPv3
RFC 3415 View-based access Control Model for SNMP
IEEE 802.1AB LLDP-MIB
IEEE 802.1 MSTP MIB

Software Tool To Manage/Schedule Firmware

Updates
N-View™ 2

Certification & Compliance

Product Safety: UL 61010 and C22.2 No. 61010 OrdLoc, UL 121201 and CSA C22.2 No. 213 Class I, Division 2 HazLoc, ATEX, IECEx and UKEx II 3 G Ex ec nC IIC T4 Gc, UL 20 ATEX 2645X, UL 22.0038X IECEx and UL22UKEX2346X
EMI/EMC: CFR 47, Part 15, Subpart B, Canada ICES-003, ANSI

www.redlion.net

NT5018-DM2 Dimensions and Specifications

C63.4, EN 61000-6-2 and 4, IEC 61000-4-2, 3, 4, 5, 6 and 8
Shock & Vibration (panel mounted) - IEC 68-2-27: 200 g @ 10 ms
Triaxial; non-operational, IEC 68-2-6: 15 g @ 5-200 Hz Triaxial;
operational
Railway/Rolling Stock - EN 50155, EN 50121 and EN 61373
Marine: ABS Type Approval for Shipboard Applications
Designed to Comply With - IEEE 1613 for Electric Utility
Substations and NEMA TS1/TS2 for Traffic Control
Other - RoHS compliant

Warranty
3 years on design and manufacturing defects.

Specifications are subject to change.
Visit www.redlion.net for more information.

Dimensions In inches [mm]

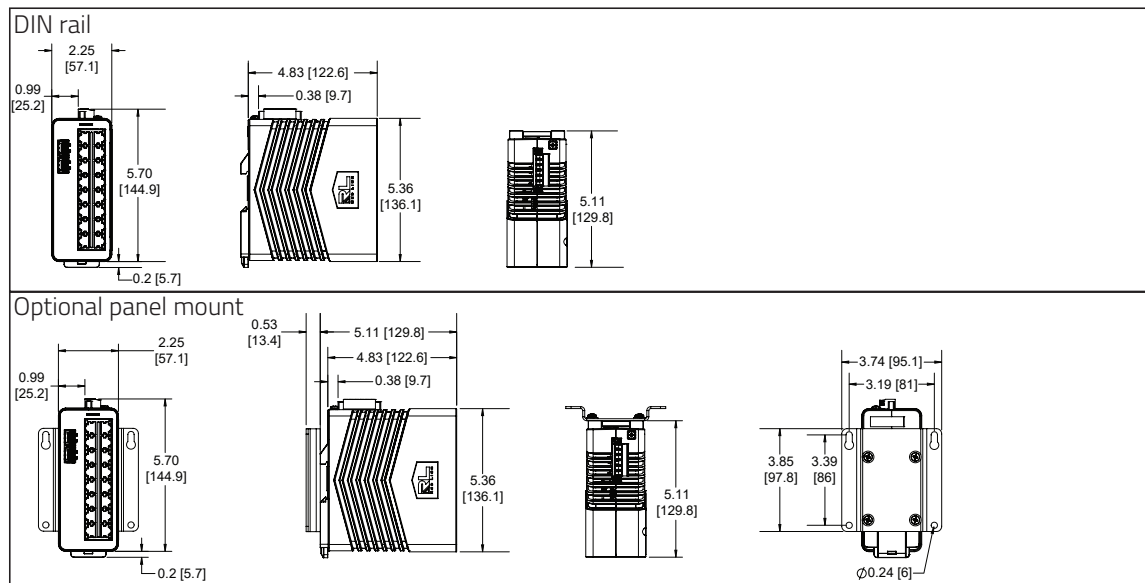

NT5018-DM2 Specifications	
Weight	1.36 lbs. (0.62 kg)
Input Voltage Range	10-49 VDC
Steady Input Range	0.58 A @ 24 VDC
BTU/hr	47.5
Operating Temperature Range	-40 to 80 °C
Storage Temperature Range	-40 to 85 °C
Humidity (non-condensing)	10 to 95% RH
Operating Altitude	0 to 10,000 ft.

Network Media Specifications	
10BaseT	≥Cat3 Cable
100BaseTX	≥Cat5 Cable
1000BaseT	≥Cat5e Cable
100BaseFX, 1000BaseSX Multimode	50-62.5/125µm
100BaseFX, 1000BaseLX Singlemode	7-10/125µm

Connectors	
10/100/1000BaseT	Sixteen (16) RJ45 copper ports
Dual Mode 100/1000Base SFP Port	Up to two (2) SFP port transceivers (SFP transceivers sold separately)

Recommended Minimum Wiring Clearance	
Front	4" (101.6 mm)
Top	4" (101.6 mm)

www.redlion.net

NT5018-DM2 Transceiver Characteristics

SFP 100Base Fiber Transceiver Characteristics

Fiber Mode	MM	SM	SM	SM
Fiber Length*	2 km	15 km	40 km	80 km
TX Power Min.	-19 dBm	-15 dBm	-5 dBm	-5 dBm
RX Sensitivity Max.	-31 dBm	-34 dBm	-34 dBm	-34 dBm
Wavelength	1310 nm	1310 nm	1310 nm	1550 nm
Laser Type	FP	FP	FP	DFB

SFP 1000Base Fiber Transceiver Characteristics

Fiber Mode	MM	SM	SM	SM
Fiber Length*	550 m @ 50/125 μ m 275 m @ 62.5/125 μ m	10 km	40 km	80 km
TX Power Min.	-9.5 dBm	-9.5 dBm	-2 dBm	0 dBm
RX Sensitivity Max.	-17 dBm	-20 dBm	-22 dBm	-24 dBm
Wavelength	850 nm	1310 nm	1310 nm	1550 nm
Laser Type	VCSEL	FP	DFB	DFB

* Fiber Length distances represent typical performance. Link budgets should be evaluated based on specific application conditions.



www.redlion.net
[contact us](#)

© 2024 Red Lion Controls, Inc. All Rights Reserved. The terms Red Lion, the Red Lion logo, N-Tron, N-View and N-Ring are trademarks or registered trademarks of Red Lion Controls. All other marks are the property of their respective owners.

LD1079C 05 2024