

Datenblatt

Trackball mit Laser-Abtastung

TSX50F8



Bezeichnung	TSX50F8
Ausführung	Frontpaneleinbau
Tastenzahl	3
Schalttechnologie	Kurzhubtasten
Cursorsteuerung	Kunststofftrackball
Technologie	Laser Abtastung
Balldurchmesser	50,8 mm
Ballmaterial	Polyester
Front	Edelstahl
Schutzgrad	IP68 frontseitig
Betriebstemperatur	-10°C ... +60°C
Abmessungen	100 x 116 x 50 mm
Schnittstelle	PS2/USB
Zusatzfunktion	herausnehmbare Kugel für einfache Reinigung
Zertifizierung	CE
Artikelnummer	TKH-TB50x-F8-MODUL
Einsatzbereich	Industrie, Gerätebau

50 MM LASER STAINLESS STEEL TRACKBALL UNIT

9 versions - IP65/IP68 sealed

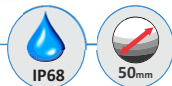

The TSX series are waterproof and vandalproof industrial trackball units and uses the latest generation of laser trackballs. These trackballs are highly suited for harsh industrial environments thanks to their robustness and ease of maintenance. They feature a removable top ring facilitating the cleaning of ball and ball compartment for use in even the most dusty environments. The concept itself of these laser trackballs make them waterproof as well.

The use of stainless steel for the various parts ensures the best resistance in salty or greasy environments. Due to its outstanding sealing, its professional style and its industrial robustness, this trackball unit is the best suited pointing device for all harsh or hostile environments, indoor and outdoor.

All panel mount types are supplied with a silicone sponge seal ring for adequate sealing into the customers' panel or console. A cover plate on the rear side protects the components.

Fields of applications are very wide : public access- and information kiosks, internet- and entertainment terminals, navigation controls, food industry, processing industries and many others.

MAIN FEATURES

- 50 mm laser trackball - vandalproof
- IP65 / IP68 sealed
- Removable top for easy cleaning of ball compartment
- Combo PS/2 & USB output

ORDER INFO

Available in 9 different versions:

PANEL MOUNT VERSION : Front panel mounting with studs or front panel mounting with holes (for countersunk M4 screws, not included)
 Choice of switches and carrier plate : IP65 pushbutton switches or IP68 short travel switches
 Choice of carrier plate : blank stainless steel carrier or matt blackened stainless steel carrier

ENCLOSED VERSION : Enclosed version : complete blank stainless steel and IP68 short travel switches



VER. 1.1

50 MM STAINLESS STEEL TRACKBALL UNIT

GENERAL TECHNICAL SPECIFICATIONS

Sealing	: IP68 waterproof
Carrier plate	: brushed stainless steel
Ball diameter	: 50,8 mm (2")
Ball material	: polyester
Dimensions / weight	
Panel mount	: 100 x 116 x 50 mm / 0,6 kg
Enclosed	: 200 x 120 x 63 mm / 1,3 kg
Lifetime	: >= 2 million ball revolutions
Tracking force	: nom. 50 grams
Output	: PS/2 & USB Combo
Cable	: 1 shielded, straight 1,6 m long
Operating temperature range:	-10°C to +60°C
Storage temperature range	: -25°C to +80°C

Switches	<u>pushbutton</u>	<u>short travel</u>
Sealing	IP65	IP68
Travel	1,3mm	0,5mm
Operating force	4N	4N
Material	stainless steel	stainless steel
Mechanical life	1 million	3 million

CE

Compliant to EMC Directive 89/336/EEC for Electromagnetic Compatibility.
Low Voltage Directive 73/23/EEC not applicable for our trackballs.

CONNECTIVITY

These combo PS/2 & USB trackball units have a 1,6 meter long shielded straight cable ended by a USB type A plug. An adaptor to PS/2 is added. No special device driver is needed, use standard available drivers of your operating system.

* Due to the increasing differences of the PS/2 mouse port specifications of the various PC manufacturers, we do recommend that this unit should be tested on the final PC configuration and operating system prior to installing it in series.

50 MM STAINLESS STEEL TRACKBALL UNIT

DIMENSIONAL DRAWING

Front panel mount with studs

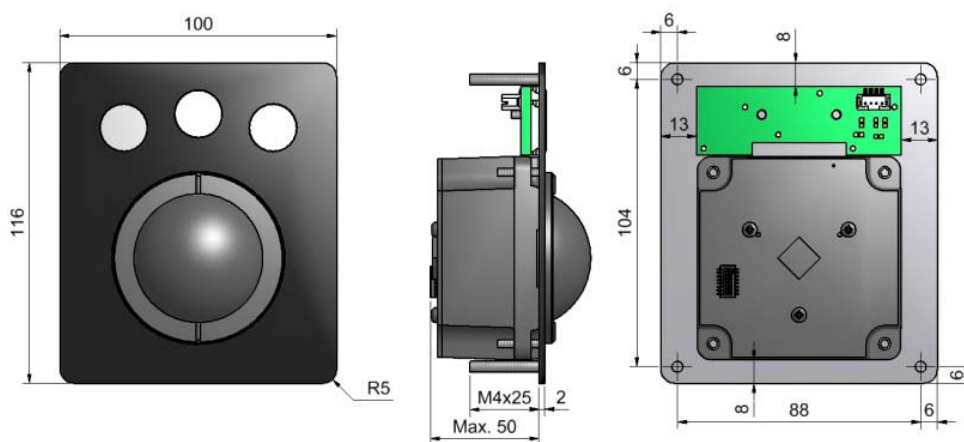

Front panel mount with holes

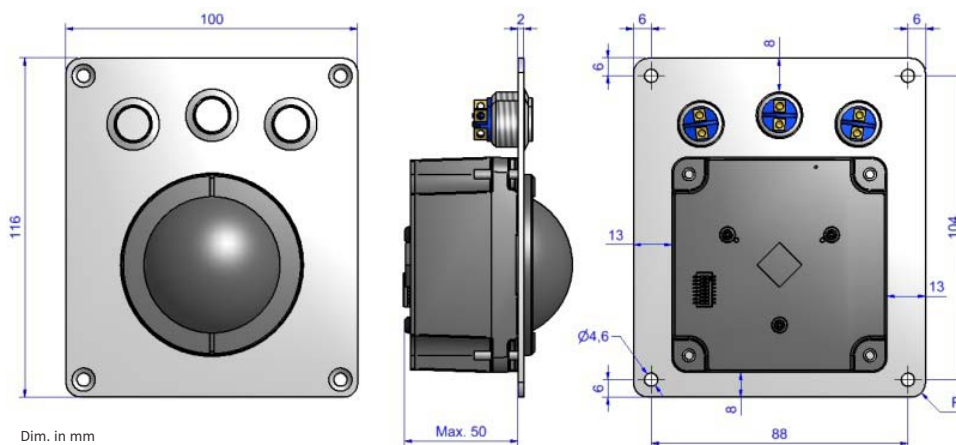

Dim. in mm

The company reserves the right to alter without prior knowledge the specification or design of any standard product or service.

VER. 1.1